

8753ES Option H39 Three-Port Test Set

User's and Service Guide

**This User's and Service Guide is intended to be used
in conjunction with the following documents.**

**8753ET/ES Network Analyzers User's Guide
Part Number: 08753-90472**

**8753ET/ES Network Analyzers Reference Guide
Part Number: 08753-90473**

**8753ET/ES Network Analyzers Service Guide
Part Number: 08753-90484**



Agilent Technologies

Manufacturing Part Number: 08753-90513

Printed in USA

Print Date: April 2001

Supersedes: January 2000

Notice

The information contained in this document is subject to change without notice. Agilent Technologies makes no warranty of any kind with regard to this material, including but not limited to, the implied warranties of merchantability and fitness for a particular purpose. Agilent Technologies shall not be liable for errors contained herein or for incidental or consequential damages in connection with the furnishing, performance, or use of this material.

Agilent Technologies assumes no responsibility for the use or reliability of its software on equipment that is not furnished by Agilent Technologies.

Restricted Rights Legend

Use, duplication, or disclosure by the U.S. Government is subject to restrictions as set forth in subparagraph (c)(1)(ii) of the Rights in Technical Data and Computer Software clause at DFARS 252.227-7013 for DOD agencies, and subparagraphs (c)(1) and (c)(2) of the Commercial Computer Software Restricted Rights clause at FAR 52.227-19 for other agencies.

© Copyright 1999–2001 Agilent Technologies, Inc.

Warranty Information

IMPORTANT

Certification

Agilent Technologies certifies that this product met its published specifications at the time of shipment from the factory. Agilent Technologies further certifies that its calibration measurements are traceable to the United States National Institute of Standards and Technology (NIST, formerly NBS), to the extent allowed by the Institute's calibration facility, and to the calibration facilities of other International Standards Organization members.

NOTE

The actual warranty on your instrument depends on the date it was ordered as well as whether or not any warranty options were purchased at that time. To determine the exact warranty on your instrument, contact the nearest Agilent Technologies sales or service office with the model and serial number of your instrument. See the list of sales and service offices in this section.

This Agilent Technologies instrument product is warranted against defects in material and workmanship for the warranty period. During the warranty period, Agilent Technologies will, at its option, either repair or replace products which prove to be defective.

If the warranty covers repair or service to be performed at the Buyer's facility, then the service or repair will be performed at the Buyer's facility at no charge within Agilent Technologies service travel areas. Outside Agilent Technologies service travel areas, warranty service will be performed at Buyer's facility only upon Agilent Technologies's prior agreement, and Buyer shall pay Agilent Technologies's round-trip travel expenses. In all other areas, products must be returned to a service facility designated by Agilent Technologies.

If the product is to be returned to Agilent Technologies for service or repair, it must be returned to a service facility designated by Agilent Technologies. Buyer shall prepay shipping charges to Agilent

Technologies and Agilent Technologies shall pay shipping charges to return the product to Buyer. However, Buyer shall pay all shipping charges, duties, and taxes for products returned to Agilent Technologies from another country.

Agilent Technologies warrants that its software and firmware designated by Agilent Technologies for use with an instrument will execute its programming instructions when properly installed on that instrument. Agilent Technologies does not warrant that the operation of the instrument, or software, or firmware will be uninterrupted or error-free.

Limitation of Warranty. The foregoing warranty shall not apply to defects resulting from improper or inadequate maintenance by Buyer, Buyer-supplied software or interfacing, unauthorized modification or misuse, operation outside of the environmental specifications for the product, or improper site preparation or maintenance.

NO OTHER WARRANTY IS EXPRESSED OR IMPLIED. AGILENT TECHNOLOGIES SPECIFICALLY DISCLAIMS THE IMPLIED WARRANTIES OF MERCHANTABILITY AND FITNESS FOR A PARTICULAR PURPOSE.

EXCLUSIVE REMEDIES

THE REMEDIES PROVIDED HEREIN ARE BUYER'S SOLE AND EXCLUSIVE REMEDIES. AGILENT TECHNOLOGIES SHALL NOT BE LIABLE FOR ANY DIRECT, INDIRECT, SPECIAL, INCIDENTAL, OR CONSEQUENTIAL DAMAGES, WHETHER BASED ON CONTRACT, TORT, OR ANY OTHER LEGAL THEORY.

8753ES Option H39 Three-Port Test Set

User's Guide

Manufacturing Part Number: 08753-90513

Printed in USA

Print Date: April 2001

Supersedes: January 2000

Contents

| | |
|---|------|
| 1. Introduction | |
| Three-Port Test Set | 1-2 |
| 2. Operation | |
| Operation | 2-2 |
| Reference Material | 2-2 |
| Front Panel Features | 2-3 |
| Operation - Option H39 Parameters | 2-5 |
| Test Set I/O Port Parameters | 2-15 |
| Sequence Commands | 2-18 |
| Operator's Check | 2-19 |
| 3. GPIB Commands and Their Measurements | |
| Example: Uncouple Channel 1 and Channel 2 | 3-3 |
| Specifications | 3-4 |
| Measurement Capabilities | 3-4 |
| Frequency Response | 3-4 |
| Raw (Uncorrected) Performance Characteristics | 3-5 |
| Measurement Characteristics (Corrected) | 3-5 |
| Output Power Characteristics | 3-6 |
| Average Noise Level | 3-6 |
| System Performance Summary | 3-7 |
| 4. Specifications | |
| Option H39 Specifications | 4-2 |
| Measurement Capabilities | 4-2 |
| Frequency Response | 4-2 |
| Raw (Uncorrected) Performance Characteristics | 4-3 |
| Measurement Characteristics (Corrected) | 4-3 |
| Output Power Characteristics | 4-4 |
| Average Noise Level | 4-4 |
| System Performance Summary | 4-5 |
| Equipment Required | 4-5 |
| Typical Measurement Uncertainty | 4-5 |

1 Introduction

Three-Port Test Set

The Option H39 is a modified 8753ES network analyzer that adds a third port to the standard instrument. The three ports allow measurement applications for three-port devices with the ability to make S-parameter measurements between any two ports.

Key sequences for setting up the analyzer use standard **Hardkey** (initial capital letters) and **SOFTKEY** (all capital letters) conventions. For a complete definition of the different keys, refer to your analyzer's standard documentation.

This user's guide provides information on how to operate the Option H39 using measurement (**Meas**) menu select ports, I/O commands, and GPIB commands, as well as examples of how to implement the commands. It also provides the specifications for the Option H39. If the Option H39 is set up or operated as a standard analyzer, refer to the standard documentation included with your shipment.

NOTE

Port 1 and Port 3 are the instrument's default ports. On preset or when the power is turned on, Port 1 and Port 3 are active.

The port status is indicated by an LED status light located to the right of each test port. Three states are indicated by the LED status light:

- Bright: Indicates the source (incident) port.
- Dim: Indicates the receive (through) port.
- Off: Indicates the port is inactive.

For further information on the status indicators, refer to ["Front Panel Features" on page 2-3](#), and Chapter 3, "Theory of Operation and Troubleshooting" of the service guide.

2

Operation

Operation

This chapter contains the following sub-sections:

- “Reference Material”
- “Front Panel Features”
- “Operation - Option H39 Parameters”
- “Test Set I/O Port Parameters”
- “Sequence Commands”
- “Option H39 Mode GPIB Commands”
- “Operator’s Check”

Reference Material

| Description | Part Number |
|--|-------------|
| <i>8753ET/ES Network Analyzers User’s Guide</i> | 08753-90472 |
| <i>8753ET/ES Network Analyzers Reference Guide</i> | 08753-90473 |
| <i>8753ET/ES Network Analyzers Service Guide</i> | 08753-90484 |
| <i>8753ET/ES Programming Guide</i> | 08753-90475 |

Front Panel Features

Figure 2-1 shows the front panel features of the analyzer.

Figure 2-1 **Option H39 Front Panel**

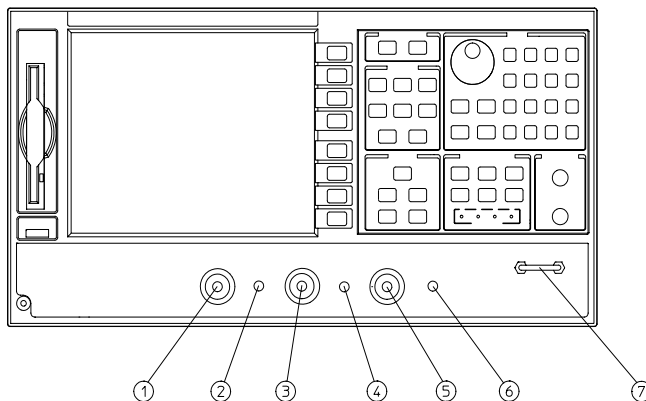

pg685h

1. Port 1
2. Port 1 status LED
3. Port 2
4. Port 2 status LED
5. Port 3
6. Port 3 status LED
7. R CHANNEL IN to R CHANNEL OUT jumper (standard on the 8753ES)

Operation
Operation

The following shows the LED status at preset or power up:

1. Port 1 LED is bright.
2. Port 2 LED is off.
3. Port 3 LED is dim.

Operation - Option H39 Parameters

“3 PORT” Mode

Firmware revisions 8753E 7.60, 8753ES 7.60 and above give the analyzer new functionality, making it easier to control the port states of the Option H39 test set. When the instrument is shipped, Option H39 is visible in the option field of the display and the 3 PORT mode is turned on. With the 3 PORT mode on, the port status can now be controlled through the Meas key and the SELEPORT GPIB commands. To turn off the 3 PORT mode, follow the System menu in Figure 2-2. Toggle the 3 PORT MODE key from ON to OFF. With the 3 PORT mode off, the functionality of the analyzer is the same as earlier versions of the firmware and is backwards compatible. To reactivate the Option H39 features, toggle the 3 PORT MODE key to ON. See Figure 2-3, “Meas Key Menu Map,” “Option H39 Mode Parameters” on page 2-8, and “Option H39 Mode GPIB Commands” on page 2-12. Other keys in the Option HXX Config menu are not active. If the keys are pressed, the message OPTION FUNCTION; NOT INSTALLED will appear.

Figure 2-2 System Key Menu Map

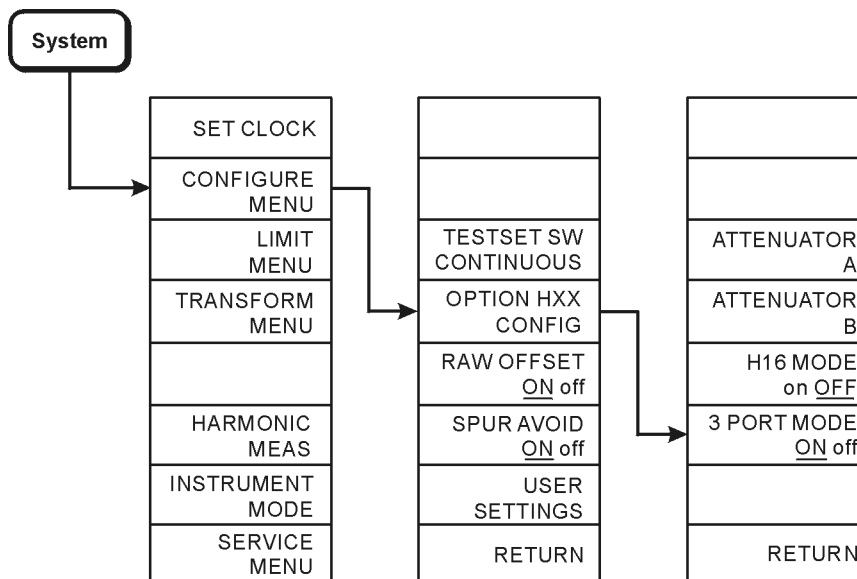

ue51 o

Measure Menu Map

Once the 3 PORT mode is turned on, control of the port states can be done through the Meas front panel key. Press the **SELECT PORTS** key to toggle between selections “PORT 1-3”, “PORT 2-3”, and “PORT 1-2”. At **Preset** or instrument turn on, the default state for selected ports is “PORT 1-3”. The **Preset** default can be overwritten by creating a user preset. See the standard documentation for details.

Figure 2-3 shows the **Meas** key menu map with the 3 PORT mode turned on. When the 3 PORT mode is turned off, the **SELECT PORTS** key is deactivated. The **Meas** key menu now functions the same as a standard analyzer.

Figure 2-3 Meas Key Menu Map

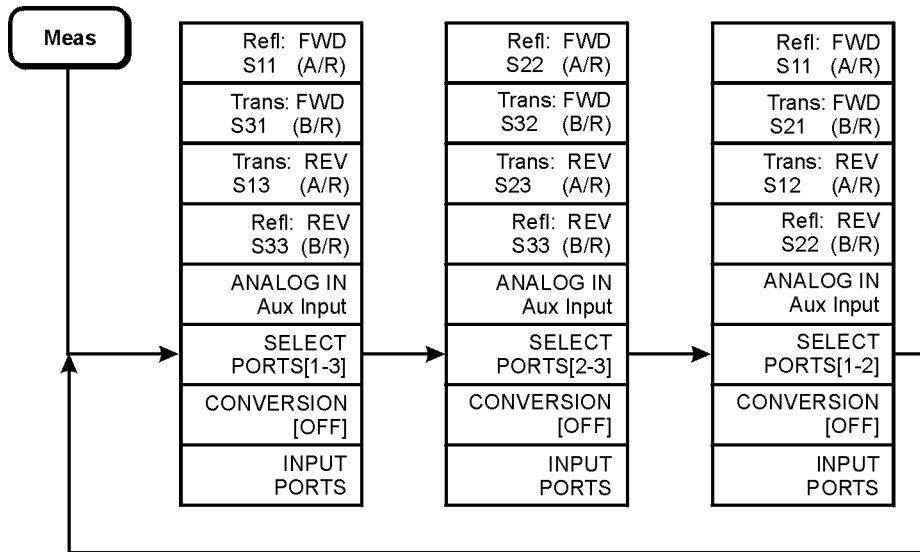

ue52o

Sequence Menu Map

With the 3 PORT mode off, the test set can be controlled by the analyzer using the sequencing key (Seq) on the front panel. Figure 2-4 shows the menus available under the Seq key.

TESTSET I/O FWD and TESTSET I/O REV control the ports.

Figure 2-4 **Seq Key Menu Map**

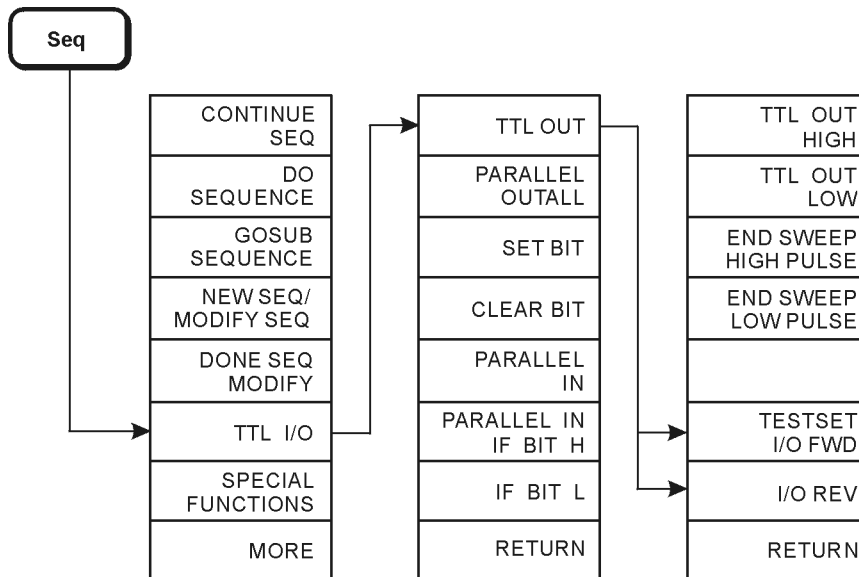

pg633h

Option H39 Mode Parameters

Table 2-1 shows the nine S-parameters and their relationship to the ports selected.

Table 2-1

Option H39 Mode Parameters

| SELECT PORTS [] | Port Paths | S-parameters Displayed |
|------------------|------------------|----------------------------------|
| 1-3 | Port 1 to Port 3 | $S_{11}, S_{31}, S_{13}, S_{33}$ |
| 2-3 | Port 2 to Port 3 | $S_{22}, S_{32}, S_{23}, S_{33}$ |
| 1-2 | Port 1 to Port 2 | $S_{11}, S_{21}, S_{12}, S_{22}$ |

When the analyzer is in dual- or quad-channel mode, uncoupling the channels uncouples channels 1 and 3 from channels 2 and 4. Channels 1 and 3 cannot be uncoupled from each other. Channels 2 and 4 cannot be uncoupled from each other. The uncoupled channels indicate the selected port S-parameter on the display. Under the **Meas** menu, the active channel shows the S-parameters that can be measured.

The Option H39 can be controlled in a number of different ways using the **3 PORT** mode. The following information is provided as a guide on how to control the analyzer in this mode:

- through the front panel menus
- through GPIB commands

The examples listed below should be used only as sample methods that can be used when setting up and controlling the analyzer.

Example: Setting the Option H39 Mode Using the Front Panel Menu

The Option H39 mode may be set up using the following front panel menu selections:

1. To turn on the Option H39 mode, press **System**, **CONFIGURE MENU**, **OPTION HXX CONFIG**, and toggle the **3 PORT MODE** key from **off** to **ON**.
2. To turn off the Option H39 mode, toggle the **3 PORT MODE** key from **on** to **OFF**.

Example: Setting the Port Selection Using the Front Panel Menu

Set the Option H39 mode port selection from Port 1 to Port 3, from Port 2 to Port 3, and from Port 1 to Port 2 using the following front panel selections:

1. Press **Meas**. The menu screen key **SELECT PORTS [1-3]** should be shown after a preset, instrument power up, or when the **3 PORT** mode is first turned on. "PORT 1-3" is the instrument default.
2. Press **SELECT PORTS [1-3]** once. The menu screen now shows **SELECT PORTS [2-3]**. The S-parameters displayed are updated to reflect Port 2 and Port 3. See [Table 2-1 on page 2-8](#).
3. Press **SELECT PORTS [2-3]**. The menu screen now shows **SELECT PORTS [1-2]**. The S-parameters displayed are updated to reflect Port 1 and Port 2. See [Table 2-1](#).
4. Press **SELECT PORTS** again to reset the Option H39 default settings.

Example: Duplexer Setup

The following example shows how to set up the analyzer to measure from Port 1 to Port 3 on channels 1 and 3, and how to measure from Port 3 to Port 2 on channels 2 and 4. In this example, steps 4 and 7 indicate where to perform a full 2-port calibration. Refer to the standard documentation for details outlining how to perform a full 2-port calibration. This example assumes the analyzer has been configured so that the default state at instrument power up or preset is in 3 PORT mode.

1. Press **Preset**.
2. Turn the coupled channel off by pressing **Sweep Setup** and toggling **COUPLED CH** from on to **OFF**.
3. Press **Chan 1**.
4. Perform a full 2-port calibration for Port 1 and Port 3. The S-parameters displayed during the calibration indicate the ports selected. After the calibration is complete, save the calibration by pressing **Save/Recall, Save State**.
5. Press **Chan 2, Meas**. Toggle **SELECT PORTS [1-3]** to **SELECT PORTS [2-3]** by pressing the **SELECT PORTS** key.
6. Perform a full 2-port calibration for Port 2 and Port 3. The S-parameters displayed during the calibration indicate the ports selected. After the calibration is complete, save the calibration by pressing **Save/Recall, Save State**.
7. Turn on the quad channel by pressing **Display, DUAL | QUAD SETUP, 4 PARM DISPLAY**. Select **SETUP A**.

With the coupled channels off and the quad-channel display on, the analyzer should show the corrected response for four of the nine S-parameters. The measurement S-parameter values are shown below:

| Channel 1, 3 | | Channel 2, 4 | |
|--------------|---------------------------|--------------|---------------------------|
| S_{11} | Port 1 Refl. | S_{22} | Port 2 Refl. |
| S_{31} | Port 1 - Port 3 FWD Trans | S_{32} | Port 2 - Port 3 FWD Trans |
| S_{13} | Port 1 - Port 3 REV Trans | S_{23} | Port 2 - Port 3 REV Trans |
| S_{33} | Port 3 Refl. | S_{33} | Port 3 Refl. |

NOTE

These examples may be saved in an instrument state and recalled later. The port settings are also saved in the instrument state.

Save the instrument state by pressing **Save/Recall**, **SAVE STATE** or **RE-SAVE STATE**.

Option H39 Mode GPIB Commands

Table 2-2 shows the Option H39 mode GPIB commands used to control the port configurations. These commands are only available for the Option H39.

Table 2-2 Option H39 Mode GPIB Commands

| GPIB Commands | Description |
|---------------|--------------------------|
| H39MODEON | Turn 3PORT mode on |
| H39MODEOFF | Turn 3PORT mode off |
| SELEPORT13 | Select Port 1 and Port 3 |
| SELEPORT23 | Select Port 2 and Port 3 |
| SELEPORT12 | Select Port 1 and Port 2 |

Table 2-3 shows the GPIB commands for selecting the S-parameters when the 3 PORT mode is on. The GPIB S-parameter commands are the same as the standard instrument. These commands show how to select the S-parameter to indicate the appropriate port parameter.

Table 2-3 GPIB Commands for S-Parameter Selection

| GPIB Commands | Select Ports 1-3 | Select Ports 2-3 | Select Ports 1-2 |
|---------------|------------------|------------------|------------------|
| S11 | S ₁₁ | S ₂₂ | S ₁₁ |
| S21 | S ₃₁ | S ₃₂ | S ₂₁ |
| S12 | S ₁₃ | S ₂₃ | S ₁₂ |
| S22 | S ₃₃ | S ₃₃ | S ₂₂ |

Example: Uncouple Channel 1 and Channel 2

In this example, the analyzer's channels are uncoupled and the selected port configurations are set independently. The display is set so both channel 1 and channel 2 are shown.

In the following commands, "Nwa" is the address of the network analyzer:

```

OUTPUT Nwa ; "PRES"           !set network analyzer to default state
OUTPUT Nwa ; "COUPOFF"       !uncouples channels
OUTPUT Nwa ; "H39MODEON"     !turn 3port mode on for H39
OUTPUT Nwa ; "SELEPORT13"    !select PORT 1 and PORT 3
OUTPUT Nwa ; "Chan
1" , "S21 : "                !set channel 1 to measure FWD S31
                             for PORT 1 and PORT 3
OUTPUT Nwa ; "Chan 2"        !select channel 2
OUTPUT Nwa ; "SELEPORT 23"   !select PORT 2 and PORT 3
OUTPUT Nwa ; "S12"           !set channel 2 to measure REV S23
                             for PORT 2 and PORT 3
OUTPUT Nwa ; "DUACON"        !dual channel display on

```

For more information on externally calibrating and controlling the analyzer, refer to the standard documentation.

NOTE

The Option H39 is a three-port test set. The current capability of the standard analyzer allows only the full 2-port calibration technique to be used. GPIB commands for calibrating the analyzer remain the same as those used to calibrate a standard instrument. When using GPIB commands, it is very important to remember which ports are selected and the states (forward or reverse) that are selected.

GPIB Calibration Scenarios

Port 1 GPIB Calibration Scenario:

Port 1 is always the forward port. S11 standards only apply.

Port 2 GPIB Calibration Scenario:

Port 1 and Port 2 can be considered Trans FWD or Refl FWD.

Port 2 and Port 3 can be considered Trans REV or Refl REV. Port 2 can be either a forward (FWD) or reverse (REV) port depending on the selected port combination. The port state selected determines if Port 2 will need S_{11} or S_{22} calibration and standards. In the case of select Port 1 and Port 2, there is no difference from the standard instrument because Port 2 is a reverse port. In the case of select Port 2 and Port 3, Port 2 needs standards for S_{11} , being that Port 2 now becomes the forward port.

Port 3 GPIB Calibration Scenario:

Port 3 is always the reverse port. S_{22} standards only apply.

Test Set I/O Port Parameters

Table 2-4 shows the nine S-parameters that can be measured with the analyzer.

Table 2-4 Test Set I/O Port Parameters

| Measurements | Ports and Port Paths | S-parameters Under Meas Menu | Test Set I/O Setting | Test Set I/O Setting |
|--------------|----------------------|------------------------------|----------------------|----------------------|
| | | | FWD | REV |
| Reflection | 1) PORT 1 | S_{11} | 7 | --- |
| | 2) PORT 2 | S_{22} | 6 | 5 |
| | 3) PORT 3 | S_{33} | --- | 7 |
| Transmission | 4) PORT 1-PORT 3 | S_{31}, S_{13} | 7 | 7 |
| | 5) PORT 2-PORT 3 | S_{32}, S_{23} | 6 | 6 |
| | 6) PORT 1-PORT 2 | S_{21}, S_{12} | 5 | 5 |

Port 1, Port 2, and Port 3 can be switched independently depending on the test set I/O forward (FWD) or reverse (REV) value and the analyzer's test state – FWD or REV. When the analyzer is in the dual-channel mode and the channels are uncoupled, the test set I/O (FWD and REV) can be set differently regardless of the FWD and REV I/O setting. The S-parameters are updated on the display when either **Chan 1** or **Chan 2** is pressed on the active channel front panel keys. S-parameters can also be updated through the **Meas** menu. After pressing the **Meas** key, select an S-parameter value (for example **Ref1: FWD S11 A/R**) to update the display.

CAUTION

Before performing a full 2-port calibration, make sure that both the TESTSET I/O FWD and the TESTSET I/O REV settings are set the same.

Operation

Operation

The analyzer can be controlled in a number of different ways. The following information is provided as a guide on how to control the analyzer:

- through the front panel menus
- through the TTL I/O sequence menu
- through test sequencing
- through GPIB commands

The examples listed should be used only as possible ways of setting up and controlling the analyzer.

Test Set I/O

The test set I/O may be set using the following keystrokes:

1. Press **Seq, TTL I/O, TTL OUT, TESTSET I/O FWD**. Enter the value setting.
2. Press **TESTSET I/O REV**. Enter the value setting. Refer to [Table 2-4 on page 2-15](#) for value settings.
3. Press **Chan 1** to update the display S-parameters. The **Chan 1** key can be found in the Active Channel key area on the front panel.

Test Set I/O Example

The following example measures a duplexer. The following keystrokes will set up the analyzer to measure from Port 1 to Port 3 on channel 1, and from Port 3 to Port 2 on channel 2. In this example, steps 4 and 8 indicate where to perform a calibration:

1. Press **System, CONFIGURE MENU, OPTION HXX CONFIG, 3 PORT MODE**, toggle from **on** to **OFF**.
2. Turn the coupled channel off by pressing **Menu, COUPLED CH OFF**.
3. Press **Chan 1**.
4. Press **Seq, TTL I/O, TTL OUT, TESTSET I/O FWD, 7, x1, TESTSET I/O REV, 7, x1**.
5. Press **Meas, Trans: FWD: REV S21 (B/R)**.
6. Perform a two-port calibration on channel 1 for Port 1 and Port 3.
7. Press **Chan 2**.

8. Press **Seq, TTL I/O, TTL OUT, TESTSET I/O FWD, 6, x1, TESTSET I/O REV, 6, x1.**
 9. Press **Meas, Trans: REV S21 B/R.**
 10. Perform a two-port calibration on channel 2 for Port 2 and Port 3.
 11. Turn on the dual channel feature by pressing **Display, DUAL CHAN ON.**
- Measurement capabilities are shown below for channel 1 and channel 2:

| Channel 1 | | Channel 2 | |
|-----------|-------------------------|-----------|-------------------------|
| S_{31} | PORT 1-PORT 3 Trans. | S_{32} | PORT 2-PORT 3 Trans. |
| S_{11} | PORT 1 Refl. | S_{22} | PORT 2 Refl. |
| S_{33} | PORT 3 Refl. | S_{33} | PORT 3 Refl. |
| S_{13} | PORT 3-PORT 1 Trans. | S_{23} | PORT 3-PORT 2 Trans. |

NOTE

These examples may be saved in an instrument state and recalled later. The port settings and TTL states are saved in the instrument state.

To save this instrument state, press **Save/Recall, SAVE STATE.**

Sequence Commands

The test set I/O may be set using the test sequencing function.

Sequence Example

The following example sets up the port configuration for Port 1 to Port 2, and for Port 2 to Port 3:

1. Press **Seq, NEW SEQ/MODIFY SEQ, SEQUENCE 1, SEQ1, TTL I/O, TTL OUT.**
2. Press **TESTSET I/O FWD, 5, x1.**
3. Press **TESTSET I/O REV, 5, x1, Chan 1.**
4. Press **RETURN, RETURN, DONE SEQ MODIFY.**
5. Press **MORE, TITLE SEQUENCE, SEQUENCE 1, SEQ 1, ERASE TITLE.**
6. Rotate the front panel knob and select the following:
P, SELECT LETTER, 1, SELECT LETTER, 2, SELECT LETTER, DONE, RETURN.
7. Press **NEW SEQ/MODIFY SEQ, SEQUENCE 2, SEQ1, TTL I/O, TTL OUT.**
8. Press **TESTSET I/O FWD, 6, x1.**
9. Press **TESTSET I/O REV, 6, x1, Chan 1.**
10. Press **RETURN, RETURN, DONE SEQ MODIFY.**
11. Press **MORE, TITLE SEQUENCE, SEQUENCE 2, SEQ2, ERASE TITLE.**
12. Rotate the front panel knob and select the following:
P, SELECT LETTER, 2, SELECT LETTER, 3, SELECT LETTER, DONE, RETURN.
13. Press **Preset.**

The softkeys on the display should show **SEQUENCE 1 P12, SEQUENCE 2 P23**. For more information about sequencing and its capabilities, refer to the standard documentation.

Pressing **SEQUENCE 1 P12** sets the analyzer to measure between Port 1 and Port 2.

Pressing **SEQUENCE 2 P23** sets the analyzer to measure between Port 2 and Port 3.

Operator's Check

Description

The operator's check consists of two softkey-initiated tests:

Port 1 Op Chk and **Port 2 Op Chk**.

A short is connected to Port 1 (Port 2, Port 3) to reflect all the source energy back into the analyzer for an S_{11} (S_{22} , S_{33}) measurement.

The first part of **Port 1 Op Chk** checks the repeatability of the transfer switch. An S_{11} measurement is stored in memory and the switch is toggled to Port 3, then back to Port 1 where another S_{11} measurement is made. The difference between the memory trace and the second trace is switch repeatability.

The remaining parts of both tests exercise the internal attenuator in 5 dB steps over a 55 dB range. The resulting measurements must be within a limit testing window to pass the test. The window size is based on source and receiver specifications.

The operator's check determines the following:

- The source is phase locked across the entire frequency range.
- All three samplers are functioning properly.
- All transfer switches and receiver switches are operational.
- The attenuator steps 10 dB at a time.

Required Equipment

Short (m)

Part of the 85032B calibration kit

Analyzer warmup time: 30 minutes

Procedure

Repeatability Check for Port 1 and Port 3

1. Disconnect all devices, peripherals, and accessories (including adapters and limiters) from the analyzer.
2. Run the test for Port 1 by pressing **Preset, PRESET: FACTORY, System, SERVICE MENU, TESTS, EXTERNAL TESTS.**

The display should show `Test 21 Port 1 Op Chk` in the active area.

3. Press **EXECUTE TEST** to begin the test.
4. At the prompt, connect the short to Port 1. Make sure the connection is tight.
5. Press **CONTINUE.**

The test is a sequence of subtests. At the end of the subtests, the test title and result will be shown. If all tests pass successfully, the overall test status will read **PASS**. If any test fails, the overall test status will read **FAIL**.

6. Run the test for Port 3 and press the step \uparrow key. The display should show `TEST 22 Port 2 Op Chk` in the active entry area.
7. Repeat steps 3 through 5.

NOTE

Do not follow the display prompt. Connect the short to Port 3.

Repeatability Check for Port 2 and Port 3

NOTE

To perform the following steps, the instrument must be in **3 PORT** mode.

1. Press **System**, **CONFIGURE MENU**, **OPTION HXX CONFIG** and toggle the **3 PORT MODE** key from **off** to **ON**.
2. Press **Meas**, **SELECT PORTS [2-3]**.
3. Run the test for Port 2 by pressing **System**, **SERVICE MENU**, **TESTS**, **EXTERNAL TESTS**.

The display should show **TEST 21 Port 1 Op Chk** in the active area.

4. Press **EXECUTE TEST** to begin the test.
5. At the prompt, connect the short to Port 2. Make sure the connection is tight.
6. Press **CONTINUE**. See note below.

The test is a sequence of subtests. At the end of the subtests, the test title and result will be shown. If all tests pass successfully, the overall test status will read **PASS**. If any test fails, the overall test status will read **FAIL**.

NOTE

Do not follow the display prompt. Connect the short to Port 2.

7. Run the test for Port 3 and press the step **↑** key. The display should show **TEST 22 Port 2 Op Chk** in the active entry area.
8. Repeat steps 4 through 6.

NOTE

Do not follow the display prompt. Connect the short to Port 3.

Repeatability Check for Port 1 and Port 2

1. Press **Meas**, **SELECT PORTS** [1-2].
2. Run the test for Port 1. Press **System**, **SERVICE MENU**, **TESTS**, **EXTERNAL TESTS**.

The display should show `TEST 21 Port 1 Op Chk` in the active area.

3. Press **EXECUTE TEST** to begin the test.
4. At the prompt, connect the short to Port 1. Make sure the connection is tight.
5. Press **CONTINUE**.

The test is a sequence of subtests. At the end of the subtests, the test title and result will be shown. If all tests pass successfully, the overall test status will read **PASS**. If any test fails, the overall test status will read **FAIL**.

6. Run the test for Port 2 and press the step \uparrow key. The display should show `TEST 22 Port 2 Op Chk` in the active entry area.
7. Repeat steps 3 through 5.
8. If all tests pass, the analyzer is about 80% verified. If any test fails, refer to the standard documentation or check the following:
 - a. Make sure that the connection is tight. Repeat the test.
 - b. Visually inspect the connector interfaces and clean them if necessary.
 - c. Verify that the short meets published specifications.
 - d. Substitute another short and repeat the test.
 - e. Refer to Chapter 3, "Theory of Operation and Troubleshooting" in the service guide.

Table 3-1 shows the GPIB commands that can be used to externally calibrate and control the port configuration for the analyzer.

Table 3-1

GPIB Commands

| GPIB Commands | Measurement |
|----------------------|---------------------------------------|
| TSTIOFWD7 | Port 1 to Port 3: S_{31} , S_{11} |
| TSTIOFWD6 | Port 2 to Port 3: S_{32} , S_{11} |
| TSTIOFWD5 | Port 1 to Port 2: S_{21} , S_{11} |
| TSTIOREV7 | Port 3 to Port 1: S_{13} , S_{33} |
| TSTIOREV6 | Port 3 to Port 2: S_{23} , S_{33} |
| TSTIOREV5 | Port 2 to Port 1: S_{12} , S_{22} |

Example: Uncouple Channel 1 and Channel 2

In this example, the analyzer's Chan1 and Chan2 are uncoupled. The Chan1 and Chan2 test set I/O FWD and I/O REV are set independently. The analyzer display is set so both Chan1 and Chan2 are displayed.

In the following commands, "Nwa" is the address of the analyzer:

```
OUTPUT Nwa; "PRES"           !
OUTPUT Nwa; "COUPOFF"        !uncouples channels
OUTPUT Nwa; "H39MODEOFF"     !turn 3PORT mode off for H39
OUTPUT Nwa; "CHAN1"; "S21"   !set channel 1 to measure S21
OUTPUT Nwa; "TSTIOFWD7"      !ports 1 and 3 selected for channel 1
OUTPUT Nwa; "TSTIOREV7"      !ports 1 and 3 selected for channel 1
OUTPUT Nwa; "CHAN2"; "S21"   !set channel 2 to measure S21
OUTPUT Nwa; "TSTIOFWD6"      !ports 2 and 3 selected for channel 2
OUTPUT Nwa; "TSTIOREV6"      !ports 2 and 3 selected for channel 2
OUTPUT Nwa; "DUACON"         !dual channel display on
```

For more information on externally calibrating and controlling the analyzer, refer to the standard documentation.

Specifications

All specifications for the Option H39 are consistent with those for the standard analyzer with the exception of the specifications found in this section.

Measurement Capabilities

| Port Paths | S-Parameter Measurements |
|-------------------------------|----------------------------------|
| Port 1 to Port 3 ^a | $S_{11}, S_{21}, S_{12}, S_{22}$ |
| Port 1 to Port 2 | $S_{11}, S_{21}, S_{12}, S_{22}$ |
| Port 2 to Port 3 | $S_{11}, S_{21}, S_{12}, S_{22}$ |

a. Default for preset and power up

Frequency Response

| Frequency Response ^a | Specification |
|---------------------------------|---------------|
| Port 1 and Port 3 | |
| 300 kHz to 3 GHz | ± 1 dB |
| 3 GHz to 6 GHz | ± 2 dB |
| Port 2^b | |
| 300 kHz to 3 GHz | 2 dB (p-p) |
| 3 GHz to 6 GHz | 4 dB (p-p) |

a. At 25 ± 5 °C

b. Peak-to-peak (p-p) deviation from nominal trace across the frequency range.

Raw (Uncorrected) Performance Characteristics

| Measurement Characteristics (Uncorrected) ^a | 30 kHz to 300 kHz ^b | 300 kHz to 1.3 GHz | 1.3 GHz to 3 GHz | 3 GHz to 6 GHz |
|---|-----------------------------------|-----------------------|---------------------|-------------------|
| Directivity | 20 dB ^c | 35 dB | 30 dB | 20 dB |
| Source Match | 10 dB ^d | 16 dB | 16 dB | 12 dB |
| Load Match ^e | 18 dB | 18 dB | 16 dB | 14 dB |
| Reflection Tracking ^f | ±3.5 dB | ±1.5 dB | ±1.5 dB | ±2.5 dB |
| Transmission Tracking ^f | ±3.5 dB | ±1.5 dB | ±1.5 dB | ±2.5 dB |
| Crosstalk | 90 dB ^g | 100 dB | 100 dB | 87 dB |

- a. Applies at 25 ±5 °C
- b. Typical
- c. 15 dB, 30 kHz to 50 kHz
- d. 10 dB, 30 kHz to 50 kHz
- e. Off-state Load Match typically ≥18 dB, 100 kHz to 3 GHz, ≥16 dB, 3 Hz to 6 GHz
- f. Deviation of nominal trace across the frequency response
- g. 60 dB, 30 kHz to 100 MHz

Measurement Characteristics (Corrected)

| Measurement Characteristics (Corrected) ^a | 30 kHz to 300 kHz ^b | 300 kHz to 1.3 GHz | 1.3 GHz to 3 GHz | 3 GHz to 6 GHz |
|---|-----------------------------------|-----------------------|---------------------|-------------------|
| Directivity | 50 dB | 50 dB | 47 dB | 40 dB |
| Source Match | 49 dB | 42 dB | 35 dB | 31 dB |
| Load Match | 50 dB | 50 dB | 47 dB | 40 dB |
| Reflection Tracking | ±0.005 dB | ±0.009 dB | ±0.019 dB | ±0.070 dB |
| Transmission Tracking | ±0.014 dB | ±0.013 dB | ±0.026 dB | ±0.065 dB |

- a. At 25 ±5 °C
- b. Typical

Output Power Characteristics

| Output Power Characteristics | Range |
|------------------------------|--------------------|
| Port 1 | |
| Standard and Option 006 | -85 dBm to +10 dBm |
| Port 2 and Port 3 | |
| Standard and Option 006 | -85 dBm to +7 dBm |

Average Noise Level

| Average Noise Level | Specification |
|-------------------------|---------------|
| 300 kHz to 3 GHz | |
| 3 kHz IF Bandwidth | -81 dB |
| 10 Hz IF Bandwidth | -102 dB |
| 3 GHz to 6 GHz | |
| 3 kHz IF Bandwidth | -76 dB |
| 10 Hz IF Bandwidth | -97 dB |

System Performance Summary

Equipment Required

| | |
|-----------------|----------|
| Calibration Kit | 85032B/E |
| Port Cables | 11857D |

Typical Measurement Uncertainty

The following graphs show the typical measurement uncertainty of a three-port device after full two-port error calibration. The curves utilize an RSS model for the contribution of residual systematic errors, dynamic accuracy, and switch repeatability. The isolation values on the curves represent the isolation that the device presents to the uncorrected port outside the measurement path.

Figure 3-1 shows the S_{21} transmission coefficient (dB) for a three-port device when the third port is terminated in the inactive port over a 300 kHz to 6 GHz frequency range.

Figure 3-1 **S_{21} Measurement Uncertainty Characteristic Curves (Corrected, Typical)**

DUT Port to Port Isolation

- Isolation = 2 dB
- △— Isolation = 10 dB
- Isolation = 20 dB
- ×— Isolation = 30 dB

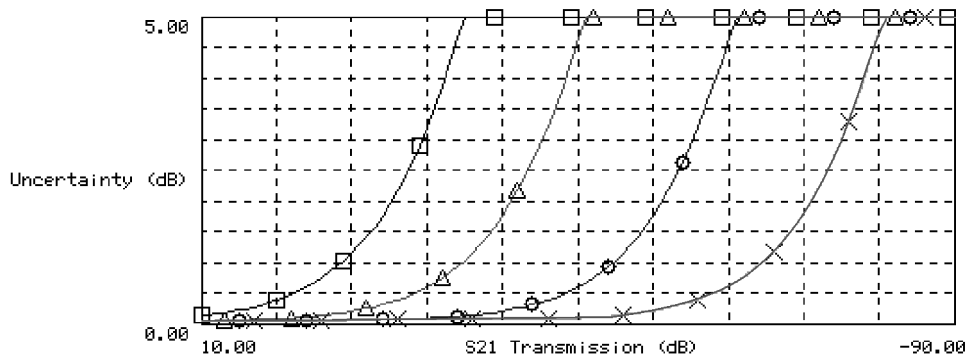

pg6128h

Figure 3-2 shows the S_{11} reflection coefficient (dB) for a three-port device when the third port is terminated in the inactive port over a 300 kHz to 6 GHz frequency range.

Figure 3-2 **S11 Measurement Uncertainty Characteristic Curves (Corrected, Typical)**

DUT Port to Port Isolation

- Isolation = 2 dB
- △ Isolation = 10 dB
- Isolation = 20 dB
- × Isolation = 30 dB

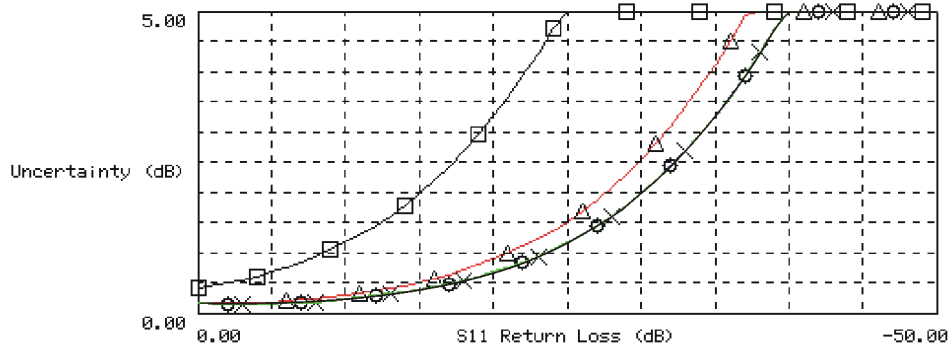

pg6127h

4 **Specifications**

Option H39 Specifications

All specifications for the Option H39 are consistent with those for the standard analyzer with the exception of the specifications found in this chapter.

Measurement Capabilities

| Port Paths | S-Parameter Measurements |
|-------------------------------|---|
| Port 1 to Port 3 ^a | S_{11} , S_{21} , S_{12} , S_{22} |
| Port 1 to Port 2 | S_{11} , S_{21} , S_{12} , S_{22} |
| Port 2 to Port 3 | S_{11} , S_{21} , S_{12} , S_{22} |

a. Default for preset and power up

Frequency Response

| Frequency Response ^a | Specification |
|---------------------------------|---------------|
| Port 1 and Port 3 | |
| 300 kHz to 3 GHz | ± 1 dB |
| 3 GHz to 6 GHz | ± 2 dB |
| Port 2^b | |
| 300 kHz to 3 GHz | 2 dB (p-p) |
| 3 GHz to 6 GHz | 4 dB (p-p) |

a. At 25 ± 5 °C

b. Peak-to-peak (p-p) deviation from nominal trace across the frequency range.

Raw (Uncorrected) Performance Characteristics

| Measurement Characteristics (Uncorrected) ^a | 30 kHz to 300 kHz ^b | 300 kHz to 1.3 GHz | 1.3 GHz to 3 GHz | 3 GHz to 6 GHz |
|---|-----------------------------------|-----------------------|---------------------|-------------------|
| Directivity | 20 dB ^c | 35 dB | 30 dB | 20 dB |
| Source Match | 10 dB ^d | 16 dB | 16 dB | 12 dB |
| Load Match ^e | 18 dB | 18 dB | 16 dB | 14 dB |
| Reflection Tracking ^f | ±3.5 dB | ±1.5 dB | ±1.5 dB | ±2.5 dB |
| Transmission Tracking ^f | ±3.5 dB | ±1.5 dB | ±1.5 dB | ±2.5 dB |
| Crosstalk | 90 dB ^g | 100 dB | 100 dB | 87 dB |

- a. Applies at 25 ±5 °C
- b. Typical
- c. 15 dB, 30 kHz to 50 kHz
- d. 10 dB, 30 kHz to 50 kHz
- e. Off-state Load Match typically ≥18 dB, 100 kHz to 3 GHz, ≥16 dB, 3 Hz to 6 GHz
- f. Deviation of nominal trace across the frequency response
- g. 60 dB, 30 kHz to 100 MHz

Measurement Characteristics (Corrected)

| Measurement Characteristics (Corrected) ^a | 30 kHz to 300 kHz ^b | 300 kHz to 1.3 GHz | 1.3 GHz to 3 GHz | 3 GHz to 6 GHz |
|---|-----------------------------------|-----------------------|---------------------|-------------------|
| Directivity | 50 dB | 50 dB | 47 dB | 40 dB |
| Source Match | 49 dB | 42 dB | 35 dB | 31 dB |
| Load Match | 50 dB | 50 dB | 47 dB | 40 dB |
| Reflection Tracking | ±0.005 dB | ±0.009 dB | ±0.019 dB | ±0.070 dB |
| Transmission Tracking | ±0.014 dB | ±0.013 dB | ±0.026 dB | ±0.065 dB |

- a. At 25 ±5 °C
- b. Typical

Output Power Characteristics

| Output Power Characteristics | Range |
|------------------------------|--------------------|
| Port 1 | |
| Standard and Option 006 | -85 dBm to +10 dBm |
| Port 2 and Port 3 | |
| Standard and Option 006 | -85 dBm to +7 dBm |

Average Noise Level

| Average Noise Level | Specification |
|-------------------------|---------------|
| 300 kHz to 3 GHz | |
| 3 kHz IF Bandwidth | -81 dB |
| 10 Hz IF Bandwidth | -102 dB |
| 3 GHz to 6 GHz | |
| 3 kHz IF Bandwidth | -76 dB |
| 10 Hz IF Bandwidth | -97 dB |

System Performance Summary

Equipment Required

| | |
|-----------------|----------|
| Calibration Kit | 85032B/E |
| Port Cables | 11857D |

Typical Measurement Uncertainty

The following graphs show the typical measurement uncertainty of a three-port device after full two-port error calibration. The curves utilize an RSS model for the contribution of residual systematic errors, dynamic accuracy, and switch repeatability. The isolation values on the curves represent the isolation that the device presents to the uncorrected port outside the measurement path.

Figure 4-1 shows the S_{21} transmission coefficient (dB) for a three-port device when the third port is terminated in the inactive port over a 300 kHz to 6 GHz frequency range.

Figure 4-1 **S_{21} Measurement Uncertainty Characteristic Curves (Corrected, Typical)**

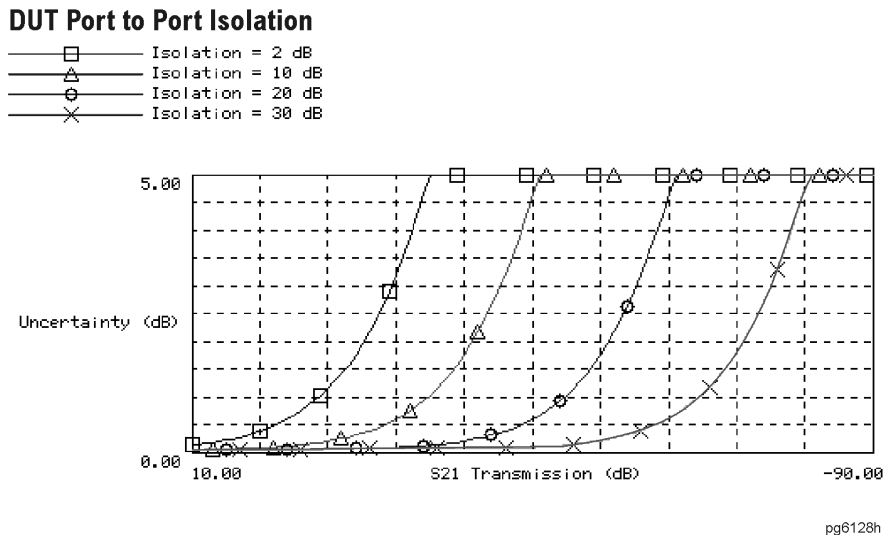

Figure 4-2 shows the S_{11} reflection coefficient (dB) for a three-port device when the third port is terminated in the inactive port over a 300 kHz to 6 GHz frequency range.

Figure 4-2 **S_{11} Measurement Uncertainty Characteristic Curves (Corrected, Typical)**

DUT Port to Port Isolation

- Isolation = 2 dB
- △ Isolation = 10 dB
- Isolation = 20 dB
- × Isolation = 30 dB



pg6127h

8753ES Option H39 Three-Port Test Set

Service Guide

Manufacturing Part Number: 08753-90513

Printed in USA

Print Date: April 2001

Supersedes: January 2000

Contents

1. System Verification and Performance Tests

| | |
|---|-------|
| Service Equipment | 1-2 |
| Introduction | 1-4 |
| How to Test the Performance of Your Analyzer | 1-5 |
| Performance Test Record Forms | 1-5 |
| General Instrument Setup Information | 1-6 |
| System Verification and Kit Recertification | 1-7 |
| System Verification | 1-8 |
| Required Equipment | 1-8 |
| Port 1 to Port 3 Initialization | 1-9 |
| Port 1 to Port 3 Measurement Calibration | 1-12 |
| Port 1 to Port 3 Device Verification | 1-14 |
| Port 2 Verification | 1-17 |
| In Case of Difficulty for Port 1 to Port 3 | 1-18 |
| Performance Tests | 1-20 |
| 1. Test Port Output Frequency Range and Accuracy | 1-21 |
| 2. External Source Mode Frequency Range | 1-24 |
| 3. Test Port Output Power Level Accuracy | 1-27 |
| 4. Test Port Output Power Linearity | 1-30 |
| 5. Minimum R Channel Level | 1-38 |
| 6. Test Port Input Noise Floor Level | 1-44 |
| 7. Test Port Input Frequency Response | 1-53 |
| 8. Test Port Crosstalk | 1-69 |
| 9. Uncorrected Port Performance | 1-80 |
| 10. System Trace Noise | 1-104 |
| 11. Test Port Receiver Magnitude Dynamic Accuracy | 1-110 |
| 12. Test Port Receiver Magnitude Compression | 1-120 |
| 13. Test Port Receiver Phase Compression | 1-123 |
| 14. Test Port Output/Input Harmonics | 1-126 |
| 15. Harmonic Measurement Accuracy | 1-132 |

Contents

2. Performance Test Records

| | |
|--|-----|
| Option H39 Performance Test Record | 2-3 |
|--|-----|

3. Theory of Operation and Troubleshooting

| | |
|---|------|
| Theory of Operation | 3-3 |
| Three-Port Test Set | 3-3 |
| Test Port Couplers | 3-3 |
| LED Front Panel | 3-4 |
| Transfer Switch S0 | 3-4 |
| Port 2 and 3 Source Switch S1 | 3-4 |
| A Sampler Receiver Switch S2 | 3-4 |
| B Sampler Receiver Switch S3 | 3-4 |
| Port 2 Receiver Switch S4 | 3-4 |
| Test Set Interface | 3-5 |
| Troubleshooting | 3-6 |
| Required Equipment | 3-6 |
| Source Test | 3-7 |
| Symptom 1: No RF Source at All Test Ports | 3-8 |
| Symptom 2: No RF Source at Port 1 | 3-9 |
| Symptom 3: RF Source at Test Port 1 | 3-10 |
| Receiver Section Test | 3-11 |
| Port 3 Test | 3-12 |
| Port 1 Test | 3-17 |
| Port 2 Test | 3-19 |

4. Replaceable Parts and Post-Repair Procedure

| | |
|---|-----|
| Replaceable Parts | 4-2 |
| Safety and Regulatory Information | 4-4 |
| General | 4-4 |
| Safety Earth Ground | 4-5 |
| Before Applying Power | 4-6 |

1 **System Verification and
Performance Tests**

Service Equipment

Table 1-1 and Table 1-2 list the tools, equipment, cables, and adapters needed when servicing, testing, or adjusting the three-port test set.

Table 1-1

Required Tools

T-8, T-10, T-15, T-20, and T-25 TORX screwdrivers

Flat-blade screwdrivers: small, medium, and large

5/16-inch open-end wrench (for SMA nuts)

2-mm extended bit allen wrench

3/16, 5/16, and 9/16-inch hex nut drivers

5/16-inch open-end torque wrench (set to 10 in-lb)

2.5-mm hex-key driver

Nonconductive and nonferrous adjustment tool

Needlenose pliers

Tweezers

Antistatic work mat with wrist strap

Table 1-2 Service Equipment

| Required Equipment | Critical Specifications | Recommended Model | Use ^a |
|----------------------------------|--|------------------------------|------------------|
| Verification Kit, 7-mm | No substitute | 85029B | P |
| Port Extension Cable Set, 7-mm | | 11857D | A, P |
| Printer | | HP ThinkJet/DeskJet/LaserJet | P |
| Adapter (3) (m) | APC-7 to Type-N | 11525A | A, P |
| Frequency Counter | 30 kHz to 500 MHz | 5350B/51B/52B | P |
| Frequency Counter | 500 MHz to 6 GHz (Option 006) | 5350B/51B/52B | P |
| Adapter | APC-3.5 (f) to Type-N (f) | P/N 1250-1745 | A, P |
| Adapter | Type-N (f) to BNC (m) | P/N 1250-1477 | P |
| External Source | Maximum spurious input: <-30 dBc Residual FM: <20 kHz | 83620A | P |
| Cable RF | APC-7, 24-inch | P/N 8120-4779 | A, P |
| Adapter | APC-3.5 (f) to APC-7 | P/N 1250-1747 | A, P |
| Adapter | APC-3.5 (m) to APC-7 | P/N 1250-1746 | A, P |
| Adapter | APC-3.5 (m) to Type-N (f) | P/N 1250-1750 | A, P |
| Cable | APC-7, 24-inch | P/N 8120-4779 | A, P |
| Power Sensor | | 8482A | A, P, T |
| Step Attenuator, 110 dB | No substitute | 8496A Option 001, H18 | P |
| Adapter | Type-N (f) to Type-N (f) | P/N 1250-0888 | P |
| Adapter | Type-N (m) to Type-N (m) | P/N 1250-1475 | P |
| Cable, GPIB | | 10833A | A |
| Diskette, 3.5 inch | any | | |
| Attenuator (2), 20 dB, Type-N | | 8491A Option 020 | P,T |
| Calibration Kit, 50 Ω Type-N | No substitute | 85032B | P |
| 50 Ω Type-N (m) Terminations (3) | No substitute | 909F | P |
| Calibration Kit, Type-N 50 Ω | No substitute | 85032B | P |
| Calibration Kit, 7-mm | No substitute | 85031B | P |
| Power Meter, (GPIB) | | 437B/438A or E4418B/4419B | A, P, T |
| Power Sensor | 3 GHz to 6 GHz | 8481A | A, P, T |
| Cable, RF (3) | 50 Ω Type-N (m) to (m) | P/N 8120-4781 | A, P |

a. P=Performance Test, A=Adjustment, T=Troubleshooting

Introduction

There are two ways to confirm that the analyzer is able to make measurements as specified. Both ways are described in this section.

The first method is the system verification procedure. With system verification, the performance of the analyzer is confirmed as a complete measurement system. The analyzer is used to measure the traceable behavior of test devices that are part of a verification kit. All of the measurement uncertainties of the analyzer, taken as a measurement system, have been accounted for in the serialized data disk shipped with the verification kit.

The second method to confirm the specified performance of the analyzer is by using the series of performance tests described in this chapter. Successful completion of an individual test confirms the specified performance of the specific subsystem tested, such as the source or receiver. Successful completion of the whole series of performance tests confirms the specified performance of the analyzer as a complete measurement system.

Key sequences for setting up the analyzer use standard **Hardkey** (initial capital letters) and **SOFTKEY** (all capital letters) conventions. For a complete definition of the different keys, refer to your analyzer's standard documentation.

For a complete description of the verification and performance test process, refer to the standard *8753ET/ES Network Analyzers Service Guide* (part number 08753-90484).

How to Test the Performance of Your Analyzer

To obtain the same quality of performance testing that Agilent Technologies has administered at the factory, you must perform one of the following:

- the system verification procedure
OR
- all of the performance test procedures.

This quality of performance testing guarantees that the analyzer is performing within all of the published specifications. A Certificate of Calibration will be issued for your analyzer if all of the following conditions are met:

1. The performance verification tests are performed by personnel qualified by Agilent.
2. Your analyzer passes all the performed tests.
3. The equipment and standards that you used to perform the tests are traceable to a national standards institute.

NOTE

If you have a particular type of measurement application that does not use all of the analyzer's measurement capabilities, you may ask your local Agilent service center for a subset of specifications that you want verified. However, this does create a potential for making incorrect measurements if you use a different application than what was specified.

Performance Test Record Forms

The appropriate performance test record forms are found in [Chapter 2, "Performance Test Records."](#)

General Instrument Setup Information

In the verification procedure, the analyzer is set up using type-N (m) to APC-7 adapters. The adapters are installed on Port 1 and Port 3. Cables are then connected to the adapters. This setup is used throughout the verification procedure. Calibration of the instrument is done with the adapters and cables attached. If the cables are removed, the calibration will be affected and the performance of the instrument will be invalid. All connections to Port 1 and Port 3 are done at the open end of the cable. The analyzer will be set up to use the turn-on and preset default ports (Port 1 and Port 3). System verification of the analyzer requires less setup by leaving the adapters and cables on the analyzer and utilizing the default settings.

NOTE

Once calibration is completed with the adapters and cables attached to the analyzer, the adapters and cables should remain on the analyzer until all of the verification procedure has been completed. If the adapters or cables are removed the calibration is affected and the performance of the instrument will be invalid.

System Verification and Kit Recertification

Agilent recommends that you verify your network analyzer measurement system every six months. Agilent also suggests that you get your verification kit recertified annually. Refer to the *85029B 7-mm Verification Kit Operating and Service Manual* for more information.

Check to see how the verification kit's floppy disk is labeled:

- If your verification disk is labeled “8753E Verification Data Disk” or “8753E and 8753ES Verification Data Disk,” you may proceed with the system verification.
- If your verification disk is not labeled as indicated above, you may send your 85029B 7-mm verification kit (which includes a data disk that you can use with the analyzer) to the nearest service center for recertification.

System Verification

Required Equipment

| Description | Model Number or Part Number |
|----------------------------------|------------------------------------|
| Calibration Kit, 7-mm | 85031B |
| Verification Kit, 7-mm | 85029B |
| Adapter (2), APC-7 to Type-N (m) | 11525A |
| Port Extension Cable Set, 7-mm | 11857D |
| Printer | HP ThinkJet/DeskJet/LaserJet |

Analyzer warmup time: 30 minutes

The following procedures are covered in this section:

- [Port 1 to Port 3 Initialization on page 1-9](#)
- [Port 1 to Port 3 Measurement Calibration on page 1-12](#)
- [Port 1 to Port 3 Device Verification on page 1-14](#)
- [Port 2 Verification on page 1-17](#)
- [In Case of Difficulty for Port 1 to Port 3 on page 1-18](#)

Port 1 to Port 3 Initialization

Instrument Setup

CAUTION

The following procedure will erase all instrument states that may be stored in internal memory.

1. Perform the following steps to save to a floppy disk any instrument states that are stored in internal memory.
 - a. Press **Save/Recall, SELECT DISK, INTERNAL MEMORY, RETURN.**
 - b. Select an instrument state and press **RECALL STATE.**
 - c. Press **SELECT DISK, INTERNAL DISK, RETURN, SAVE STATE.**
 - d. If the instrument state file was not saved to disk with the same name that it had while in internal memory, you may wish to rename the file.
2. Clear all internal memory. Press **System, SERVICE MENU, PEEK/POKE, RESET MEMORY, Preset.**
3. Connect the following equipment to Port 1 and Port 3 of the analyzer as shown in [Figure 1-1](#).

Adapter (2), APC-7 to Type-N (m) 11525A

Port Extension Cable Set, 7-mm 11857D

Analyzer warmup time: 30 minutes

Figure 1-1 System Verification Test Setup

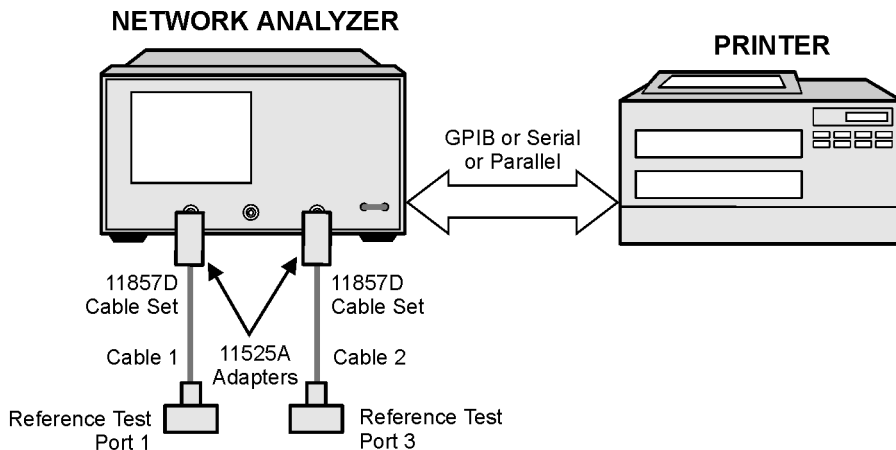

ue53o

1. While the equipment is warming up, review “Principles of Microwave Connector Care” in the standard 8753ES service guide. Good connections and clean, undamaged connectors are critical for accurate measurement results.
2. Insert the verification kit disk into the analyzer disk drive.
3. Press **Preset**, **Save/Recall**, **SELECT DISK**, **INTERNAL DISK**.
4. If you want a printout of the verification data for all the devices, press **System**, **SERVICE MENU**, **TEST OPTIONS**, **RECORD ON**.

CAUTION

If you switch on the record function, you *cannot* switch it off during the verification procedure.

5. Position the paper in the printer so printing starts at the top of the page.

6. If you have difficulty with the printer:
 - a. If the interface on your printer is GPIB, verify that the printer address is set to 1 (or change the setting in the analyzer to match that of the printer).
 - b. If the interface on your printer is serial or parallel, be sure that you selected the printer port and the printer type correctly (refer to the standard documentation for more information on how to perform these tasks).
7. Press **System**, **SERVICE MENU**, **TESTS**, **SYS VER TESTS**, **EXECUTE TEST**.
8. The analyzer displays `Sys Ver Init DONE`. The initialization procedure is complete.

CAUTION

Do not press **Preset** or recall another instrument state. You must use the instrument state loaded during the initialization procedure.

Port 1 to Port 3 Measurement Calibration

1. Press **Cal**, **CAL KIT**, **SELECT CAL KIT**, **CAL KIT:7mm**, **RETURN**, **RETURN**, **CALIBRATE MENU**, **FULL 2-PORT**.
2. Press **ISOLATION**, **OMIT ISOLATION**.
3. Press **REFLECTION**.
4. Connect the open to reference test port 1 as shown in [Figure 1-2](#).

Figure 1-2

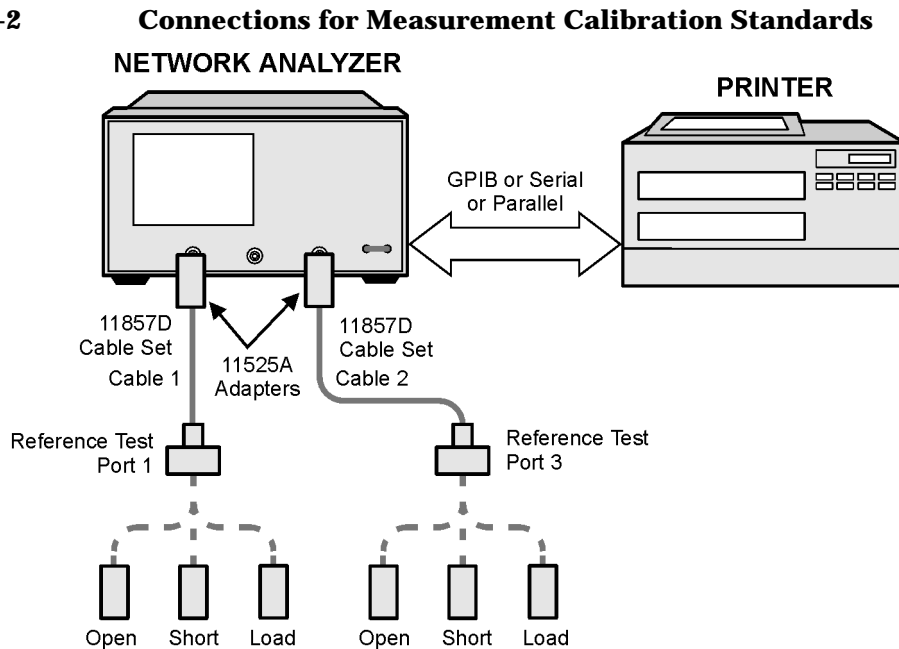

5. Press **FORWARD:OPEN**.
 - a. When the analyzer finishes measuring the standard, connect the short to reference test port 1.
 - b. Press **FORWARD:SHORT**.
 - c. When the analyzer finishes measuring the standard, connect the 50 Ω termination (supplied in the calibration kit) to reference test port 1.
 - d. Press **FORWARD:LOAD**

6. When the analyzer finishes measuring the standard, connect the open to reference test port 3.
 - a. Press **REVERSE:OPEN**.
7. When the analyzer finishes measuring the standard, connect the short to reference test port 3.
 - a. Press **REVERSE:SHORT**.
 - b. When the analyzer finishes measuring the standard, connect the 50Ω termination to reference test port 3.
 - c. Press **REVERSE:LOAD**.
 - d. When the analyzer finishes measuring the standard, press **STANDARDS DONE**.
8. The analyzer should briefly display **COMPUTING CAL COEFFICIENTS**.

Figure 1-3

Transmission Calibration Setup

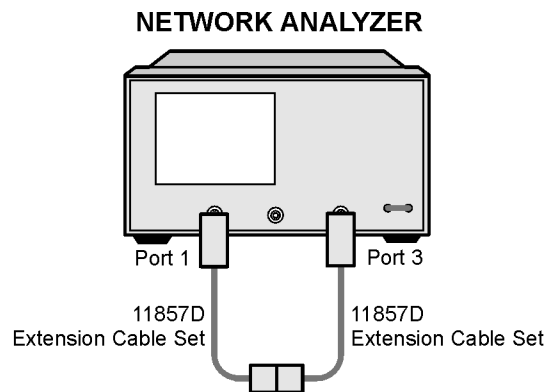

ue55o

9. Connect the port cables as shown in [Figure 1-3](#).
10. Press **TRANSMISSION, DO BOTH FWD + REV**.
11. Press **DONE 2-PORT CAL**.

System Verification and Performance Tests

System Verification

12. Press **Save/Recall**, **SELECT DISK**, **INTERNAL MEMORY**, **RETURN**, **SAVE STATE** to save the calibration in the analyzer internal memory.
13. When the analyzer finishes saving the instrument state, press **SELECT DISK**, **INTERNAL DISK**.

Port 1 to Port 3 Device Verification

1. Press **System**, **SERVICE MENU**, **TESTS 28**, **x1**, **EXECUTE TEST**.
2. At the prompt, connect the 20 dB attenuator (supplied in the verification kit) as shown in [Figure 1-4](#).
3. Press **CONTINUE** to run the test:
 - a. If you switched off the record function, you must press **CONTINUE** after each S-parameter measurement.
 - b. If you switched on the record function, the analyzer measures all S-parameters (magnitude and phase) without pausing. The analyzer only displays and prints the PASS/FAIL information for the S-parameter measurements that are valid for system verification.

Figure 1-4

Connections for the 20 dB Verification Test

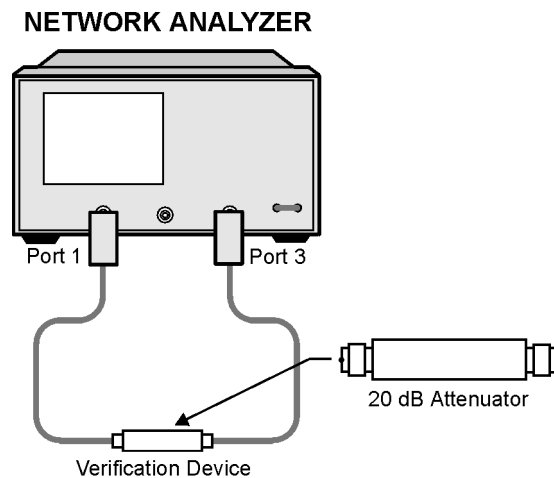

ue56o

- When the analyzer finishes all the measurements, connect the 50 dB attenuator (supplied in the verification kit), as shown in [Figure 1-5](#).

Figure 1-5

Connections for the 50 dB Verification Device

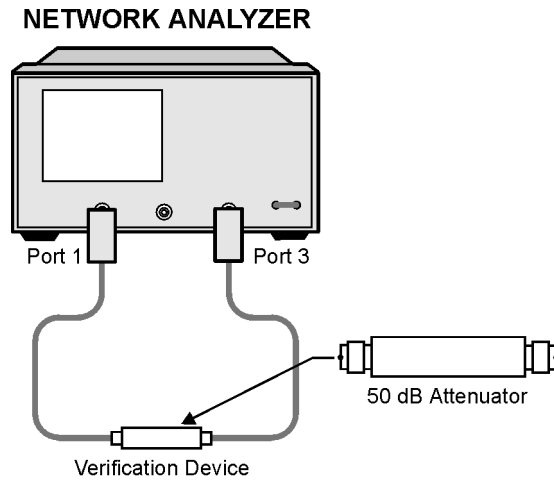

ue57o

- Press ↓ , 29, x1, EXECUTE TEST, CONTINUE.

- When all measurements are complete, replace the verification device with the verification mismatch, as shown in [Figure 1-6](#). Be sure to connect Port A of the verification mismatch to Port 3.

Figure 1-6

Mismatch Device Verification Setup 1

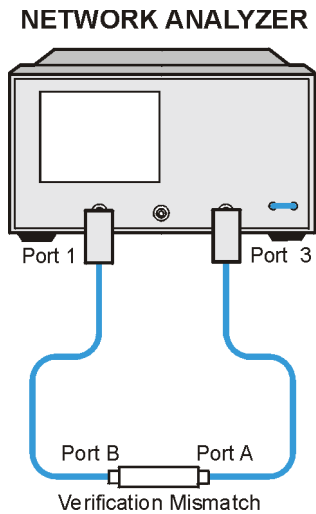

ue59o

- Press **RETURN, TESTS, 30, x1, EXECUTE TEST, CONTINUE.**

- When the analyzer finishes all the measurements, connect the mismatch verification device as shown in [Figure 1-7](#). Notice that Port B is now connected to reference test port 1.

Figure 1-7

Mismatch Device Verification Setup 2

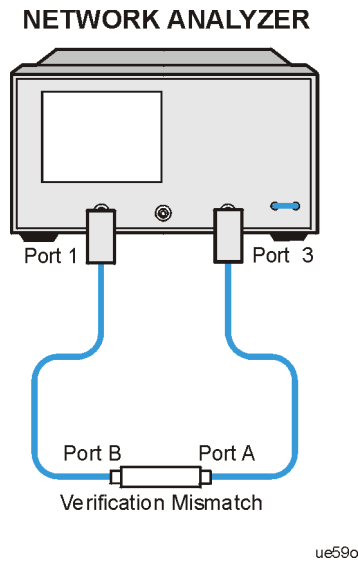

- Press **RETURN, TESTS, 31, x1, EXECUTE TEST, CONTINUE**.
- You have completed the system verification procedure when the analyzer displays `Ver Def 4 DONE`.

Port 2 Verification

Perform the Port 2 verification to ensure the proper operation of the analyzer. Port 2 verification consists of doing all the Port 2 to Port 3 and Port 1 to Port 2 verification tests in [“9. Uncorrected Port Performance”](#) on [page 1-80](#), found in the performance test records.

In Case of Difficulty for Port 1 to Port 3

1. Inspect all connections.

CAUTION

Do not disconnect the cables from the reference test ports. Doing so will invalidate the calibration you performed earlier.

2. Press **Preset**, **Save/Recall**, **SELECT DISK**, **INTERNAL MEMORY**, **RETURN**. Using the front panel knob, highlight the title of the full 2-port calibration performed earlier, then press **RECALL STATE**.
3. Repeat procedure “[Port 1 to Port 3 Device Verification](#)” on page 1-14.
4. If the analyzer still fails the test, check the measurement calibration as follows:
 - a. Press **Preset**.
 - b. Recall the calibration by pressing **Save/Recall**, **SELECT DISK**, **INTERNAL MEMORY**, **RETURN**.
 - c. Use the front panel knob to highlight the calibration you want to recall and press **RECALL STATE**.
 - d. Connect the short to reference test port 1.
 - e. Press **Meas**, **Ref!**: **FWD S11 (A/R)**, **Menu**, **TRIGGER MENU**, **CONTINUOUS**.
 - f. Press **Scale Ref**, **SCALE/DIV**, **.05**, **x1**.
 - g. Check that the trace response is 0.00 ± 0.05 dB.
 - h. Disconnect the short and connect it to reference test port 3.
 - i. Press **Meas**, **Ref!**: **REV S22(B/R)**.
 - j. Check that the trace response is 0.00 ± 0.05 dB.
 - k. If any of the trace responses are out of the specified limits, repeat the “[Port 1 to Port 3 Measurement Calibration](#)” on page 1-12 and the “[Port 1 to Port 3 Device Verification](#)” on page 1-14.

5. Refer to [Chapter 3, "Theory of Operation and Troubleshooting,"](#) for information regarding specialized troubleshooting of the Option H39.
6. Refer to the analyzer's standard documentation for additional troubleshooting information.

Performance Tests

To ensure that the analyzer performs as specified, complete all of the listed performance tests.

The following performance tests are in this section:

1. Test Port Output Frequency Range and Accuracy on page 1-21
2. External Source Mode Frequency Range on page 1-24
3. Test Port Output Power Level Accuracy on page 1-27
4. Test Port Output Power Linearity on page 1-30
5. Minimum R Channel Level on page 1-38
6. Test Port Input Noise Floor Level on page 1-44
7. Test Port Input Frequency Response on page 1-53
8. Test Port Crosstalk on page 1-69
9. Uncorrected Port Performance on page 1-80
10. System Trace Noise on page 1-104
11. Test Port Receiver Magnitude Dynamic Accuracy on page 1-110
12. Test Port Receiver Magnitude Compression on page 1-120
13. Test Port Receiver Phase Compression on page 1-123
14. Test Port Output/Input Harmonics on page 1-126
15. Harmonic Measurement Accuracy on page 1-132

1. Test Port Output Frequency Range and Accuracy

Perform this test to verify the frequency accuracy of the analyzer over its entire operating frequency range.

Specifications

| Frequency Range | Frequency Accuracy ^a |
|-----------------------------|---------------------------------|
| 30 kHz to 3 GHz | ± 10 ppm |
| 3 GHz to 6 GHz ^b | ± 10 ppm |

a. At 25 ± 5 °C

b. Only for analyzers with Option 006

Required Equipment

| Description | Model Number or Part Number |
|------------------------------------|-----------------------------|
| Frequency Counter | 5350B/51B52B |
| Cable, 50Ω Type-N, 24-inch | part number 8120-4781 |
| Adapter, APC-2.5 (f) to Type-N (f) | part number 1250-1745 |
| Adapter, Type-N (f) to BNC (m) | part number 1250-1477 |

Analyzer warmup time: 30 minutes

1. Connect the equipment as shown in [Figure 1-8](#).

Figure 1-8

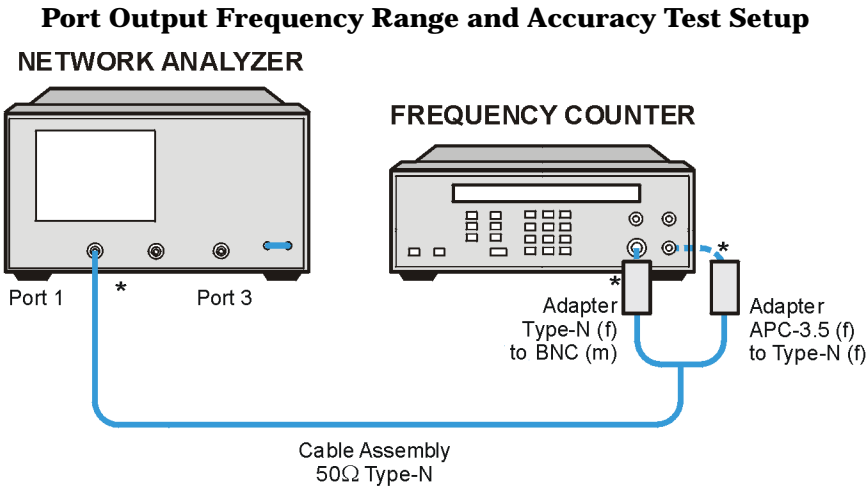

* Direct Connection

ue510o

2. Press **Preset, Sweep Setup, CW FREQ.**
3. Press **30, k/m** and write the frequency counter reading in the performance test record.
4. Repeat step 3 for each instrument frequency listed in the performance test record.

In Case of Difficulty

1. If any measured frequency is close to the specification limits, check the time-base accuracy of the counter used.

If the analyzer fails by a significant margin at all frequencies (especially if the deviation increases with frequency), the master time base probably needs adjustment. In this case, refer to the standard documentation for more information about frequency accuracy adjustment. The “Fractional-N Frequency Range Adjustment” also affects frequency accuracy.

2. Refer to [Chapter 3, "Theory of Operation and Troubleshooting,"](#) in this service guide for information regarding the specialized troubleshooting of the Option H39 analyzer.
3. Refer to the troubleshooting information in the analyzer's standard documentation.

2. External Source Mode Frequency Range

Perform this test to verify that the analyzer's reference channel, input R, is capable of phase locking to an external CW signal.

Specifications

| |
|------------------------------|
| Frequency Range |
| 30 kHz to 3 GHz |
| 30 kHz to 6 GHz ^a |

- a. Only for analyzers with Option 006

Required Equipment

| Description | Model Number |
|-------------------------------|-----------------------|
| External Source | 83620A |
| Cable, APC-7, 24-inch | part number 8120-4779 |
| Adapter, APC-3.5 (f) to APC-7 | part number 1250-1747 |
| Adapter, APC-3.5 (m) to APC-7 | part number 1250-1746 |

Analyzer warmup time: 30 minutes

1. On the external source, press **Preset, CW, 10, MHz/μsec, POWER LEVEL, -/←, 20, GHz/dB(m)**.
2. Connect the equipment as shown in **Figure 1-9**.

Figure 1-9 External Source Mode Frequency Range Test Setup

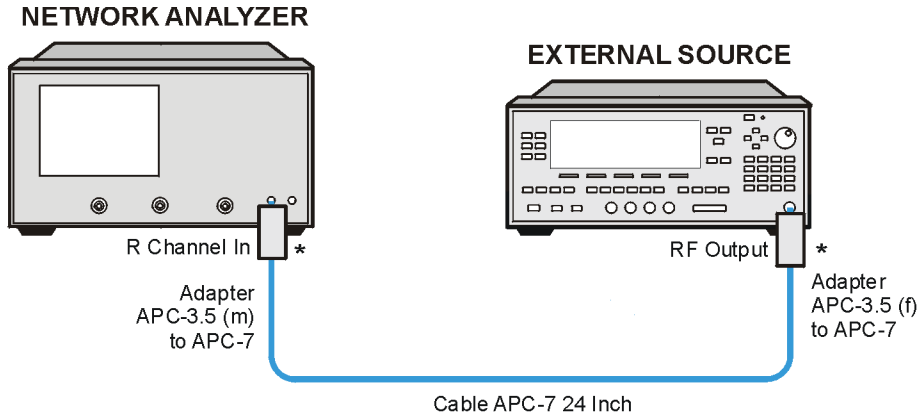

* Direct Connection

ue511o

3. On the analyzer, press **Preset, Meas, INPUT PORTS, R**.
4. Press **System, INSTRUMENT MODE, EXT SOURCE AUTO, Sweep Setup, CW FREQ, 10, M/μ**.
5. Check to see if the analyzer is phase locking to the external CW signal:
 - a. If the analyzer displays any phase lock error messages, write "unlock" on the performance test record for the set CW signal.
 - b. If the analyzer does not display any phase lock error messages, write "lock" on the performance test record for the set CW signal.
6. On the external source, press **CW, 20, MHz/μsec**.
7. On the analyzer, press **20, M/μ**.
8. Repeat steps 5 through 7 for the other external source CW frequencies listed in the performance test record.

In Case of Difficulty

If the analyzer displayed any phase lock error messages:

1. Be sure the external source power is set within 0 to -25 dBm.
2. Make sure the analyzer's "Ext Source Auto" feature is selected. In addition, verify that the analyzer is set to measure its input R channel.
3. Verify that all connections are tight.

3. Test Port Output Power Level Accuracy

Perform this test to confirm the accuracy of the 8753ES test port output power. A power meter is used to determine the output level from Port 1. This measurement is compared to the level set by the network analyzer. The difference must be within the specified tolerance.

Analyzer warmup time: 30 minutes

Specifications

| Frequency Range | Test Port Output Power Accuracy ^a |
|-----------------------------|--|
| 300 kHz to 3 GHz | ±1.0 dB |
| 3 GHz to 6 GHz ^b | ±1.0 dB |

a. At 0 dBm and 25° C ±5° C

b. Only for analyzers with Option 006

Required Equipment

| Description | Model Number |
|--|--------------------------------|
| Power Meter | 436A/437B/438A or E4418B/4419B |
| Power Sensor | 8482A |
| Additional Equipment for Option 006 Analyzers | |
| Power Sensor | 8481A |

Procedure

1. Zero and calibrate the power meter. For more information of how to perform this task, refer to the power meter operating manual.
2. Connect the equipment as shown in [Figure 1-10](#).

Figure 1-10 Test Port Output Power Level Accuracy Test Setup

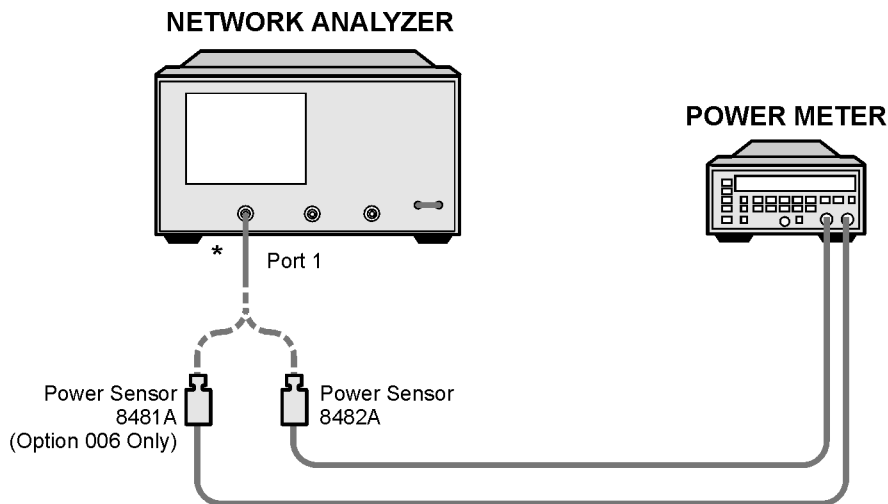

* Direct Connection

ue512o

3. Press **Preset**.

NOTE

The factory preset test port power is 0 dBm.

4. Press **Sweep Setup, CW FREQ, 30, k/m**. Set the calibration factor on the power meter for this CW frequency.
5. Write the power meter reading on the performance test record.
6. Repeat steps 4 and 5 for each CW frequency listed in the performance test record. For analyzers with Option 006, use the 8481A power sensor for all frequencies above 3 GHz.

In Case of Difficulty

1. Be sure the source power is switched on. Press **Power**. Check the **SOURCE PWR** softkey; ON should be highlighted. Otherwise, press **SOURCE PWR** to switch on the source power.
2. Refer to [Chapter 3, "Theory of Operation and Troubleshooting,"](#) for more troubleshooting information.

4. Test Port Output Power Linearity

Specifications

| Power Range | Power Level Linearity ^a |
|---------------|------------------------------------|
| -15 to +5 dBm | ±0.2 dB |
| +5 to +10 dBm | ±0.5 dB |
| +5 to +8 dBm | ±0.5 dB |

- a. Relative to 0 dBm from 300 kHz to 3 GHz
(6 GHz for Option 006).

Required Equipment

This test verifies the analyzer's port output power linearity throughout the analyzer's frequency range. A power meter calibration is used to set the reference output power. Subsequent measurements are made with the analyzer's Port 2 receiver.

| Description | Model Number or Part Number |
|--|------------------------------|
| Power Meter | 437B/438A or E4418B/4419B |
| Power Sensor | 8482A |
| Attenuator, APC-7, 50Ω, 20 dB | 8492A Opt. 020 |
| RF Cable, APC-7, 50Ω | part number 8120-4781 |
| GPIB Cable | 10833A/B/C/D |
| Additional Equipment Required for Analyzers with Option 006 | |
| Power Sensor | 8481A |

Output Power Linearity

Before the output power linearity readings are made, a power meter calibration is performed. The power meter calibration accurately sets the output power of the analyzer's source to 0 dBm. This "corrected" 0 dBm output is then used as the reference for measuring the other output power levels from the source.

Power Meter Calibration

1. Zero and calibrate the power meter.
2. Connect the equipment as shown in [Figure 1-11](#) with the following exceptions:
 - If your analyzer is a standard 8753ES (operation to 3 GHz), connect only the 8482A power sensor to the power meter.
 - If your analyzer has Option 006 (operation to 6 GHz), connect both power sensors to the power meter. At this time, connect only the 8482A power sensor to the analyzer.

Figure 1-11 Setup for Power Meter Calibration on Port 1

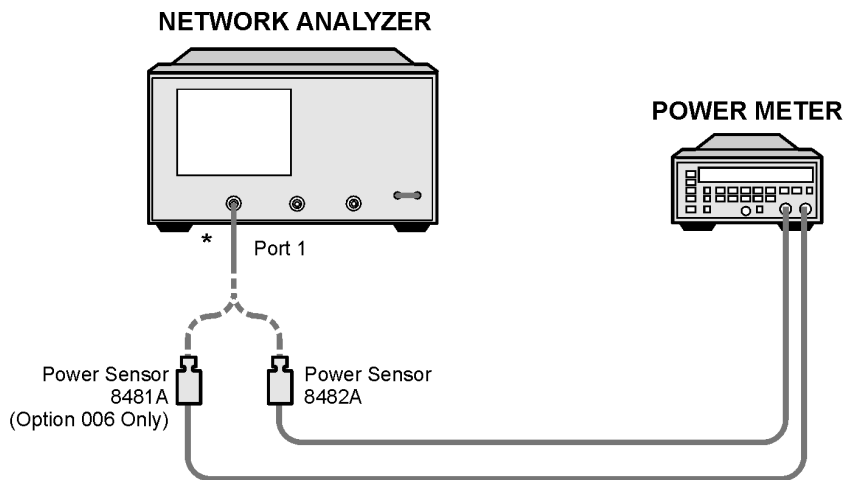

* Direct Connection

ue512o

System Verification and Performance Tests

Performance Tests

3. Press **Preset**.
4. Press **Avg, IF BW, 100, x1, Sweep Setup, NUMBER of POINTS, 51, x1**.
5. Press **Start, 300, k/m** then:
 - If the analyzer has Option 006, press **Stop, 3, G/n**.
6. Press **Local, SYSTEM CONTROLLER**.
7. Press **SET ADDRESSES** and **POWER MTR** until the analyzer shows the correct power meter model.
8. Press **ADDRESS:P MTR/GPIB**. The default power meter GPIB address is 13. Make sure it is the same as your power meter GPIB address. Otherwise, use the analyzer front panel keypad to enter the correct GPIB address for your power meter.
9. Press **Power, PWR RANGE AUTO**, then toggle from **man** to **MAN** to turn the auto power range off.

NOTE

The analyzer displays the PRM annotation, indicating that the analyzer power range is set to **MANUAL**.

10. Press **PORT POWER** to uncouple the port output power.
11. Press **Cal, PWRMTR CAL**.
12. Press **LOSS/SENSR LISTS, CAL FACTOR SENSOR A**. Refer to the back of the power sensor to locate the different calibration factor values along with their corresponding frequencies.

NOTE

The analyzer's calibration factor sensor table can hold a maximum of 55 calibration factor data points.

The following softkeys are included in the sensor calibration factor entries menu:

| | |
|-------------------|--|
| SEGMENT | Press to select a point where you can use the front panel knob or entry keys to enter a value. |
| EDIT | Press to edit or change a previously entered value. |
| DELETE | Press to delete a point from the sensor calibration factor table. |
| ADD | Select this key to add a point into the sensor calibration factor table. |
| CLEAR LIST | Select this key to erase the entire sensor calibration factor table. |
| DONE | Select this key when done entering points to the sensor calibration factor table. |

The following keystrokes are used as an example for entering the first two calibration factor data points for the 8482A power sensor (assuming CF% = 96.4 at 100 kHz and CF% = 98.4 at 300 kHz):

- a. From the sensor calibration factor entries menu, press **ADD**.
- b. Press **FREQUENCY, 100, k/m**. If you make an entry error, press ← and re-enter the correct value again.
- c. Press **CAL FACTOR, 96.4, x1**.
- d. Press **DONE** to terminate the first calibration factor data point entry.
- e. To enter the second cal factor data point, press **ADD**.
- f. Press **FREQUENCY, 300, k/m**.
- g. Press **CAL FACTOR, 98.4, x1**.
- h. To terminate the second calibration factor data point entry, press **DONE**.
- i. Press **SEGMENT** and use the front panel knob to scroll through the sensor calibration factors table. Check to be sure all values are entered correctly. If you see an error, use the front panel knob to point to the data point you want to modify and press **EDIT**.

System Verification and Performance Tests

Performance Tests

- j. Press the appropriate softkeys and create a power sensor calibration factors table.
- k. Press **DONE** to exit the sensor calibration factor entries menu.
- l. Press **RETURN, ONE SWEEP, TAKE CAL SWEEP** to start the power meter calibration.

NOTE

The analyzer displays the PC annotation indicating the power meter calibration is done and the error correction is active.

Output Power Linearity Measurement: 300 kHz to 3 GHz

1. Set up the equipment as shown in [Figure 1-12](#).

Figure 1-12 Port Output Power Level Linearity Test Setup

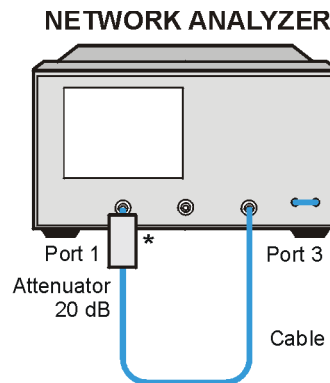

ue513o

2. Press **Meas, INPUT PORTS, B**.
3. Press **Sweep Setup, TRIGGER MENU, SINGLE**.
4. Press **Display, DATA → MEMORY, DATA/MEM**.
5. Press **Power, -15** (or the next power setting from the performance test record), **x1**.
6. Press **Sweep Setup, TRIGGER MENU, SINGLE**.

7. Press **Marker**, Δ **MODE MENU**, **FIXED MKR POSITION**, **FIXED MKR VALUE**, **-15** (or the next power setting from the performance test record), **x1**, **RETURN**, Δ **REF = Δ FIXED MKR**.
8. Press **Marker**, **1**, **Marker Search**, **SEARCH: MAX**, **Marker**, **2**, **Marker Search**, **MIN**.
9. Read the value for marker 1 from the display and enter it in the performance test record in the “Marker 1 Maximum” column. Enter the value of Marker 2 in the “Marker 2 Minimum” column.
10. Repeat steps 5 through 8 for all power settings in the 300 kHz to 3 GHz range listed on the performance test record.
11. The marker 1 and marker 2 readings should be within the specified range for each power level with reference to the fixed marker value.
12. If your analyzer does not have Option 006, this ends the test. If you have problems with this test, proceed to [“In Case of Difficulty” on page 1-37](#).
13. If your analyzer has Option 006, proceed to [“Power Meter Calibration from 3 GHz to 6 GHz,”](#) next.

Power Meter Calibration from 3 GHz to 6 GHz

1. Disconnect the 8482A power sensor from the analyzer and connect the 8481A power sensor in its place.
2. Press **Start**, **3, G/n**, **Stop**, **6, G/n**.
3. Press **Cal**, **PWRMTR CAL**.
4. Press **LOSS/SENSR LISTS**, **CAL FACTOR SENSOR B**. Refer to [“Power Meter Calibration” on page 1-31](#) to build a sensor calibration factor table for the 8481A power sensor (sensor B).
5. Press **DONE** to exit the sensor calibration factor entries menu.
6. Press **USE SENSOR B** to select the 8481A sensor.
7. Press **RETURN**, **TAKE CAL SWEEP** to start the power meter calibration.

Output Power Linearity Measurement from 3 GHz to 6 GHz

1. Set up the equipment as shown in [Figure 1-13](#).

Figure 1-13 Port Output Power Level Linearity Test Setup

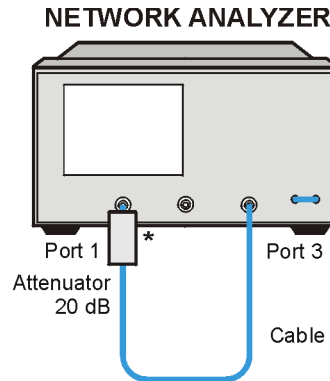

* Direct Connection

ue513o

2. Press **Meas**, **INPUT PORTS**, **B**.
3. Press **Sweep Setup**, **TRIGGER MENU**, **SINGLE**.
4. Press **Display**, **DATA** → **MEMORY**, **DATA/MEM**.
5. Press **Power**, **-15**, **x1**.
6. Press **Sweep Setup**, **TRIGGER MENU**, **SINGLE**.
7. Press **Marker**, **Δ** **MODE MENU**, **FIXED MKR POSITION**, **FIXED MKR VALUE**, **-15**, **x1**, **RETURN**, **Δ** **REF = Δ** **FIXED MKR**.
8. Press **Marker**, **1**, **Marker Search**, **SEARCH: MAX**, **Marker**, **2**, **Marker Search**, **MIN**.
9. Read the value for marker 1 from the display and enter it in the performance test record in the “Marker 1 Maximum” column. Enter the value of Marker 2 in the “Marker 2 Minimum” column.
10. Repeat steps 5 through 9 for all power levels listed on the performance test record in the 3 GHz to 6 GHz range.
11. The marker 1 and 2 readings should be within the specified range for each power level with reference to the fixed marker value.

12. This ends the test. If you have problems, refer to “[In Case of Difficulty](#),” next.

In Case of Difficulty

1. Ensure that the power meter and power sensor(s) are operating to specifications. Be sure you set the power meter calibration factor for the range of frequencies you are testing.
2. Verify there is power coming out of the analyzer's test port 1. Be sure you did not accidentally switch off the analyzer's internal source. If you did so, press **Power, SOURCE PWR ON** to turn back on the internal source.
3. Repeat this performance test.

5. Minimum R Channel Level

Perform this test to determine the minimum R channel input power level that phase lock can be accomplished.

Specifications

| Frequency Range | Minimum R Channel Level |
|-----------------------------|-------------------------|
| 300 kHz to 3 GHz | <-35 dBm |
| 3 GHz to 6 GHz ^a | <-30 dBm |

a. Only for analyzers with Option 006

Required Equipment

| Description | Model Number or Part Number |
|------------------------------------|-----------------------------|
| Cable, 50Ω, Type-N, 24-inch | part number 8120-4781 |
| Adapter, APC 3.5 (m) to Type-N (f) | part number 1250-1750 |

Analyzer warmup time: 1 hour

1. Connect the equipment as shown in [Figure 1-14](#).

Figure 1-14

Minimum R Channel Level Test Setup

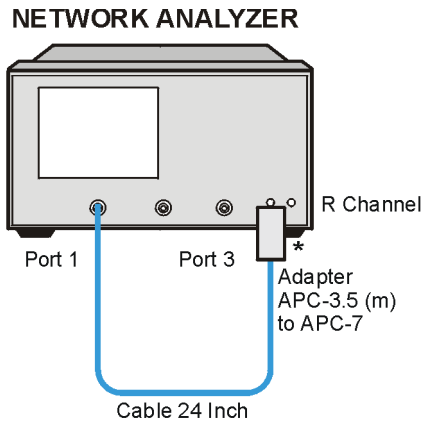

ue514c

2. Press **Preset, Meas, INPUT PORTS, R**.
3. Press **Power, PWR RANGE MAN, POWER RANGES, RANGE 5 -65 to -40**.
4. Press **Scale Ref, REFERENCE VALUE, -70, x1**.
5. Press **Sweep Setup, CW FREQ, 300, k/m**.
6. Press **Power, -65, x1**.

The analyzer displays the message **CAUTION: NO IF FOUND: CHECK R INPUT LEVEL**.

7. Press **↑** to increase the port power by 1 dBm.
8. If the analyzer displays a phase lock error message, continue increasing the port power until phase lock is achieved.
9. Write the port power that is displayed on the analyzer on the performance test record.
10. Repeat steps 5 through 9 for the other CW frequencies listed in the performance test record.

In Case of Difficulty

1. Check the flexible RF cable (W8 as shown in [Figure 1-15 on page 1-41](#) between the R sampler assembly (A4) and the A11 phase lock assembly). Make sure it is connected between A11J1 (PL IF IN) and 1st IF Out.

CAUTION

Do not push cable W8 down next to the A11 phase lock assembly.

Figure 1-15 **Flexible RF Cable Location**

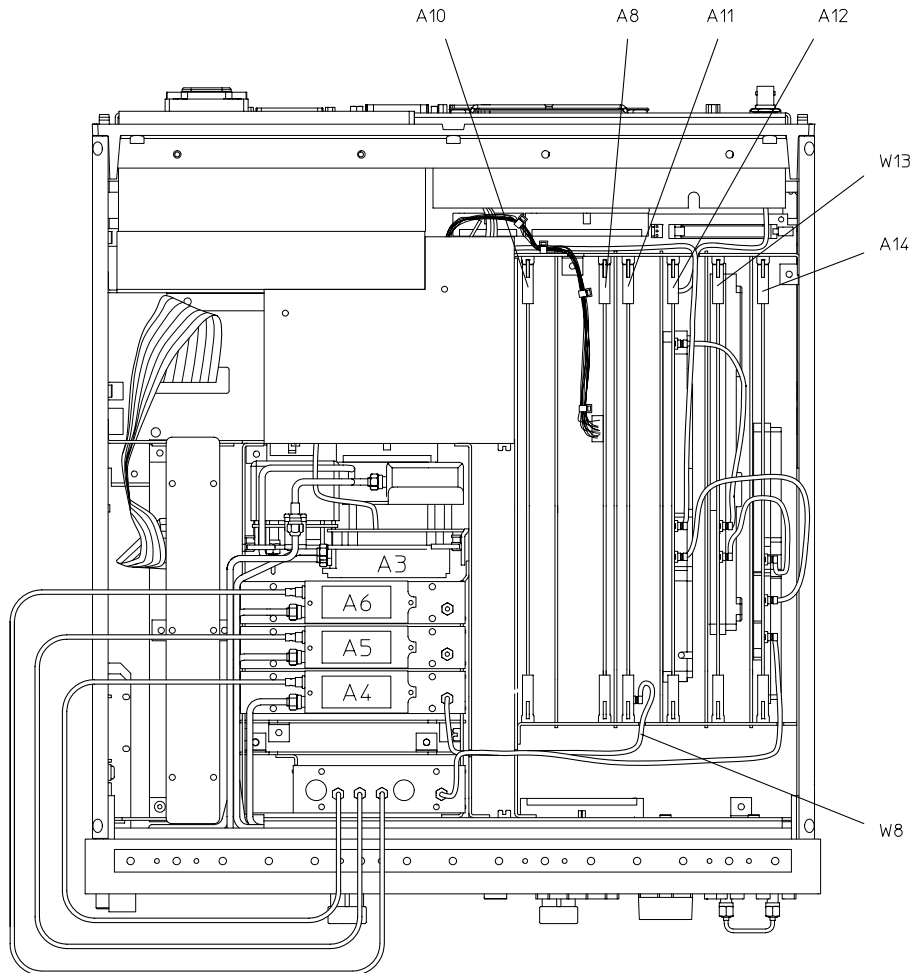

sg686e

2. Remove the W8 RF cable. Refer to [Figure 1-15](#) and the standard documentation for instructions on how to remove and install the W8 RF cable.
3. Using an ohmmeter, verify the RF cable is not open. Examine both cable connectors. Measure the resistance between the cable center pin and the cable connector and make sure it is not close to zero.

Figure 1-16 **B Sampler**

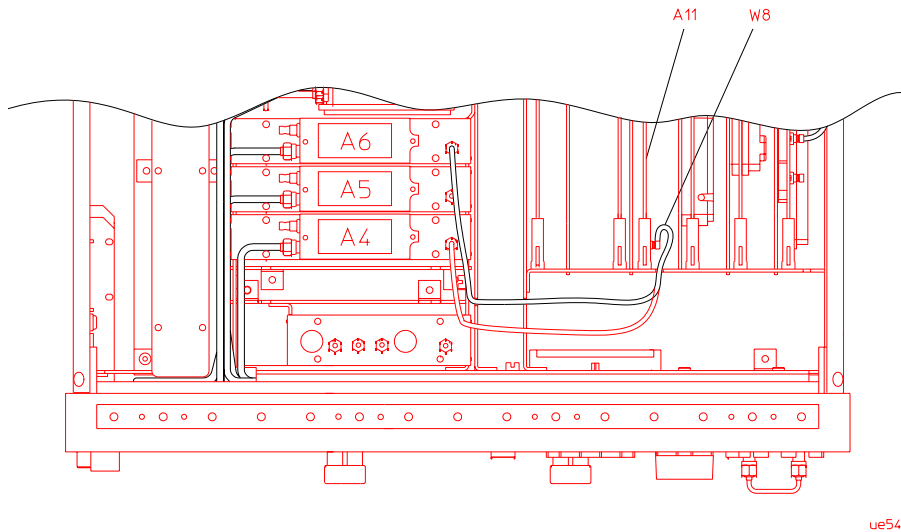

4. Check the R sampler by substituting it with the B sampler (A6).
 - a. Move cable W8 to the B sampler (A6) as shown in [Figure 1-17 on page 1-43](#).

5. Connect the equipment as shown in [Figure 1-17](#).

Figure 1-17 Setup for Checking the R Sampler (A4)

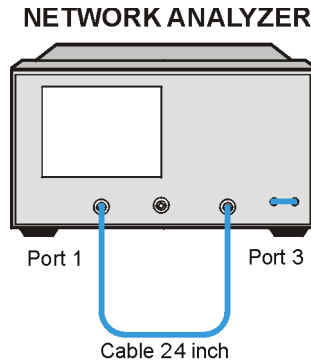

ue515c

6. Repeat the test, but select the B sampler (A6) by pressing **Meas, INPUT PORTS, B**. Use the following specifications:
300 kHz to 3 GHz \leftarrow 27 dBm
3 GHz to 6 GHz \leftarrow 22 dBm
7. If the analyzer fails the test, replace the A11 assembly.
Verify that the high/low band adjustments are still within specifications. For more information on how to perform this task, refer to the "High/Low Band Transition Adjustment" information located in the standard documentation.
8. Refer to [Chapter 3, "Theory of Operation and Troubleshooting,"](#) for information regarding specialized troubleshooting for the analyzer.

6. Test Port Input Noise Floor Level

Perform this test to determine the Port 1, Port 2, and Port 3 noise floor levels at the input ports.

NOTE

Port 1 and Port 3 are separated into four measurements (two IF bandwidths per each frequency range with two frequency ranges being measured).

Port 2 is separated into eight different measurements consisting of two IF bandwidths per each frequency range on two channel paths — channel A and channel B. Channel A is the path from Port 2 to the A sampler. Channel B is the path from Port 2 to the B sampler. Each channel path (A or B) is then separated into four measurements (two IF bandwidths per each frequency range, with two frequency ranges being measured). This totals the eight different measurements being done for Port 2.

Specifications

| Frequency Range | Port | IF Bandwidth | Average Noise Level |
|---------------------------------|---------------------|--------------|---------------------|
| 300 kHz to 3.0 GHz | Port 1 | 3 kHz | -81 dBm |
| 300 kHz to 3.0 GHz | Port 1 | 10 Hz | -102 dBm |
| 300 kHz to 3.0 GHz | Port 2 ^a | 3 kHz | -81 dBm |
| 300 kHz to 3.0 GHz | Port 2 ^a | 10 Hz | -102 dBm |
| 300 kHz to 3.0 GHz | Port 3 | 3 kHz | -81 dBm |
| 300 kHz to 3.0 GHz | Port 3 | 10 Hz | -102 dBm |
| 3.0 GHz to 6.0 GHz ^b | Port 1 | 3 kHz | -76 dBm |
| 3.0 GHz to 6.0 GHz ^b | Port 1 | 10 Hz | -97 dBm |
| 3.0 GHz to 6.0 GHz ^b | Port 2 ^a | 3 kHz | -76 dBm |
| 3.0 GHz to 6.0 GHz ^b | Port 2 ^a | 10 Hz | -97 dBm |
| 3.0 GHz to 6.0 GHz ^b | Port 3 | 3 kHz | -76 dBm |
| 3.0 GHz to 6.0 GHz ^b | Port 3 | 10 Hz | -97 dBm |

a. A and B channel noise floor

b. Only for analyzers with Option 006

Required Equipment

| Description | Model Number or Part Number |
|---------------------------------|-----------------------------|
| 50Ω Type-N (m) Terminations (3) | 909F, Option 012 |

Analyzer warmup time: 1 hour

Port 1 Noise Floor Level from 300 kHz to 3 GHz (IF BW = 3 kHz)

1. Connect the equipment as shown in [Figure 1-18](#).

Figure 1-18

Source Input Noise Floor Test Setup

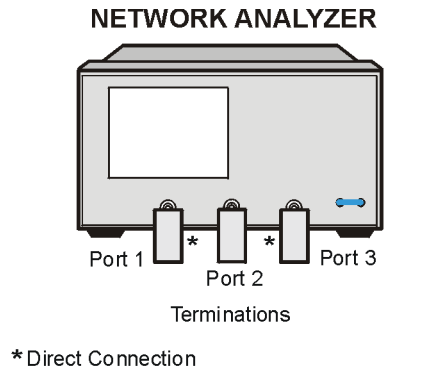

ue516c

2. Press **Preset**.
3. Press **Meas, SELECT PORTS [1-2]**.
4. Press **Avg, IF BW, 3, k/m, Power, -85, x1, Stop, 3, G/n**.
5. Press **Meas, INPUT PORTS, A, TESTPORT 2, Format, LIN MAG, Scale Ref, AUTO SCALE**.
6. Press **Marker Fctn, MARKER MODE MENU, STATS ON, Sweep Setup, TRIGGER MENU, SINGLE**.
7. When the analyzer finishes the sweep, notice the mean value that appears on the analyzer display.
8. Convert the measured linear magnitude mean value to log magnitude using the following equation:

$$\text{Power (dBm)} = 20 \times [\log_{10}(\text{linear magnitude mean value})]$$

NOTE

Notice that the mean value displayed on the analyzer is in μ Units. If the displayed value is $62\mu\text{U}$, the value you would put in the equation is (62×10^{-6}) .

9. Write this calculated value on the performance test record.

**Port 1 Noise Floor Level from 300 kHz to 3 GHz
(IF BW = 10 Hz)**

1. Press **Avg, IF BW, 10, x1** to change the IF bandwidth to 10 Hz.
2. Press **Sweep Setup, TRIGGER MENU, SINGLE**.
3. When the analyzer finishes the sweep, notice the mean value.
4. Convert the measured linear magnitude mean value to log magnitude using the following equation:

$$Power (dBm) = 20 \times [\log_{10}(\text{linear magnitude mean value})]$$

5. Write this calculated value on the performance test record.

**Port 2B Channel Noise Floor Level from 300 kHz to 3 GHz
(IF BW = 10 Hz)**

1. Press **Meas, INPUT PORTS, B, TESTPORT 1, Format, LIN MAG**.
2. Press **Sweep Setup, TRIGGER MENU, SINGLE**.
3. When the analyzer finishes the sweep notice the mean value.
4. Convert the measured linear magnitude mean value to log magnitude using the following equation:

$$Power (dBm) = 20 \times [\log_{10}(\text{linear magnitude mean value})]$$

5. Write this calculated value on the performance test record.

**Port 2B Channel Noise Floor Level from 300 kHz to 3 GHz
(IF BW = 3 kHz)**

1. Press **Avg, IF BW, 3, k/m** to change the IF bandwidth to 3 kHz.
2. Press **Sweep Setup, TRIGGER MENU, SINGLE**.
3. When the analyzer finishes the sweep, notice the mean value.
4. Convert the measured linear magnitude mean value to log magnitude using the following equation:

$$Power (dBm) = 20 \times [\log_{10}(\text{linear magnitude mean value})]$$

5. Write this calculated value on the performance test record.

Performance Tests

6. If your analyzer does not have Option 006, this completes the procedure. Proceed to “Port 2A Channel Noise Floor Level from 300 kHz to 3 GHz (IF BW = 3 kHz)” on page 1-49. If you have Option 006 in your analyzer, proceed to the next section.

**Port 2B Channel Noise Floor Level from 3 GHz to 6 GHz
(IF BW = 3 kHz)**

1. Press **Start, 3, G/n, Stop, 6, G/n**.
2. Press **Sweep Setup, TRIGGER MENU, SINGLE**.
3. When the analyzer finishes the sweep, notice the mean value.
4. Convert the measured linear magnitude mean value to log magnitude using the following equation:

$$Power (dBm) = 20 \times [\log_{10}(\text{linear magnitude mean value})]$$

5. Write this calculated value on the performance test record.

**Port 2B Channel Noise Floor Level from 3 GHz to 6 GHz
(IF BW = 10 Hz)**

1. Press **Avg, IF BW, 10, x1** to change the IF bandwidth to 10 Hz.
2. Press **Sweep Setup, TRIGGER MENU, SINGLE**.
3. When the analyzer finishes the sweep, notice the mean value.
4. Convert the measured linear magnitude mean value to log magnitude using the following equation:

$$Power (dBm) = 20 \times [\log_{10}(\text{linear magnitude mean value})]$$

5. Write this calculated value on the performance test record.

**Port 1 Noise Floor Level from 3 GHz to 6 GHz
(IF BW = 10 Hz)**

1. Press **Meas, INPUT PORTS, A, TESTPORT 2**.
2. Press **Sweep Setup, TRIGGER MENU, SINGLE**.
3. When the analyzer finishes the sweep, notice the mean value.

4. Convert the measured linear magnitude mean value to log magnitude using the following equation:

$$\text{Power (dBm)} = 20 \times [\log_{10}(\text{linear magnitude mean value})]$$

5. Write this calculated value on the performance test record.

**Port 1 Noise Floor Level from 3 GHz to 6 GHz
(IF BW = 3 kHz)**

1. Press Avg, IF BW, 3, k/m.
2. Press Sweep Setup, TRIGGER MENU, SINGLE.
3. When the analyzer finishes the sweep, notice the mean value.
4. Convert the measured linear magnitude mean value to log magnitude using the following equation:

$$\text{Power (dBm)} = 20 \times [\log_{10}(\text{linear magnitude mean value})]$$

5. Write this calculated value on the performance test record.

**Port 2A Channel Noise Floor Level from 300 kHz to 3 GHz
(IF BW = 3 kHz)**

1. Press Preset.
2. Press Seq, TTL I/O, TTL OUT, TESTSET I/O FWD, 6, x1, I/O REV, 6, x1.
3. Press Avg, IF BW, 3, k/m, Power, -85, x1, Stop, 3, G/n.
4. Press Meas, INPUT PORTS, A, TESTPORT 2, Format, LIN MAG, Scale Ref, AUTO SCALE.
5. Press Marker Fctn, MARKER MODE MENU, STATS ON, Sweep Setup, TRIGGER MENU, SINGLE.
6. When the analyzer finishes the sweep, notice the mean value that appears on the analyzer's display.
7. Convert the measured linear magnitude mean value to log magnitude using the following equation:

$$\text{Power (dBm)} = 20 \times [\log_{10}(\text{linear magnitude mean value})]$$

NOTE

Note the mean value displayed on the analyzer is in μ Units. If the displayed value is $62\mu\text{U}$, the value you would put in the equation is (62×10^{-6}) .

8. Write this calculated value on the performance test record.

**Port 2A Channel Noise Floor Level from 300 kHz to 3 GHz
(IF BW = 10 Hz)**

1. Press **Avg, IF BW, 10, x1** to change the IF bandwidth to 10 Hz.
2. Press **Sweep Setup, TRIGGER MENU, SINGLE**.
3. When the analyzer finishes the sweep, notice the mean value.
4. Convert the measured linear magnitude mean value to log magnitude using the following equation:

$$\text{Power (dBm)} = 20 \times [\log_{10}(\text{linear magnitude mean value})]$$

5. Write this calculated value on the performance test record.

**Port 3 Noise Floor Level from 300 kHz to 3 GHz
(IF BW = 10 Hz)**

1. Press **Meas, INPUT PORTS, B, TESTPORT 1, Format, LIN MAG**.
2. Press **Sweep Setup, TRIGGER MENU, SINGLE**.
3. When the analyzer finishes the sweep notice the mean value.
4. Convert the measured linear magnitude mean value to log magnitude using the following equation:

$$\text{Power (dBm)} = 20 \times [\log_{10}(\text{linear magnitude mean value})]$$

5. Write this calculated value on the performance test record.

**Port 3 Noise Floor Level from 300 kHz to 3 GHz
(IF BW = 3 kHz)**

1. Press **Avg, IF BW, 3, k/m** to change the IF bandwidth to 3 kHz.
2. Press **Sweep Setup, TRIGGER MENU, SINGLE**.

3. When the analyzer finishes the sweep, notice the mean value.
4. Convert the measured linear magnitude mean value to log magnitude using the following equation:
$$\text{Power (dBm)} = 20 \times [\log_{10}(\text{linear magnitude mean value})]$$
5. Write this calculated value on the performance test record.
6. If your analyzer does not have Option 006, this completes the test port input noise floor level procedure. If you have Option 006 in your analyzer, continue with the following procedures.

**Port 3 Noise Floor Level from 3 GHz to 6 GHz
(IF BW = 3 kHz)**

1. Press **Start, 3, G/n, Stop, 6, G/n**.
2. Press **Sweep Setup, TRIGGER MENU, SINGLE**.
3. When the analyzer finishes the sweep, notice the mean value that appears on the analyzer display.
4. Convert the measured linear magnitude mean value to log magnitude using the following equation:
$$\text{Power (dBm)} = 20 \times [\log_{10}(\text{linear magnitude mean value})]$$
5. Write this calculated value on the performance test record.

**Port 3 Channel Noise Floor Level from 3 GHz to 6 GHz
(IF BW = 10 Hz)**

1. Press **Avg, IF BW, 10, x1** to change the IF bandwidth to 10 Hz.
2. Press **Sweep Setup, TRIGGER MENU, SINGLE**.
3. When the analyzer finishes the sweep, notice the mean value.
4. Convert the measured linear magnitude mean value to log magnitude using the following equation:
$$\text{Power (dBm)} = 20 \times [\log_{10}(\text{linear magnitude mean value})]$$
5. Write this calculated value on the performance test record.

**Port 2A Channel Noise Floor Level from 3 GHz to 6 GHz
(IF BW = 10 Hz)**

1. Press **Meas**, **INPUT PORTS**, **A**, **TESTPORT 2**.
2. Press **Sweep Setup**, **TRIGGER MENU**, **SINGLE**.
3. When the analyzer finishes the sweep, notice the mean value.
4. Convert the measured linear magnitude mean value to log magnitude using the following equation:

$$\text{Power (dBm)} = 20 \times [\log_{10}(\text{linear magnitude mean value})]$$

5. Write this calculated value on the performance test record.

**Port 2A Channel Noise Floor Level from 3 GHz to 6 GHz
(IF BW = 3 kHz)**

1. Press **Avg**, **IF BW**, **3**, **k/m**.
2. Press **Sweep Setup**, **TRIGGER MENU**, **SINGLE**.
3. When the analyzer finishes the sweep, notice the mean value.
4. Convert the measured linear magnitude mean value to log magnitude using the following equation:

$$\text{Power (dBm)} = 20 \times [\log_{10}(\text{linear magnitude mean value})]$$

5. Write this calculated value on the performance test record.

In Case of Difficulty

1. Perform the ADC linearity correction constants (Test 52) located in the standard documentation.
2. Repeat procedure: [“6. Test Port Input Noise Floor Level” on page 1-44.](#)
3. Suspect the A10 Digital IF assembly if the analyzer fails both port input noise floor tests.
4. Refer to the troubleshooting information in the standard documentation.
5. Refer to [Chapter 3, “Theory of Operation and Troubleshooting,”](#) for information regarding specialized troubleshooting for the analyzer.

7. Test Port Input Frequency Response

Perform this test to determine the receiver's frequency response flatness.

Specifications

| Frequency Range | Port | Input Frequency Response |
|-----------------------------|---------------------|--------------------------|
| 300 kHz to 3 GHz | Port 1 | ± 1 dB |
| 300 kHz to 3 GHz | Port 2 ^a | 2 dB (p-p) |
| 300 kHz to 3 GHz | Port 3 | ± 1 dB |
| 3 GHz to 6 GHz ^b | Port 1 | ± 2 dB |
| 3 GHz to 6 GHz ^a | Port 2 ^a | 4 dB (p-p) |
| 3 GHz to 6 GHz ^a | Port 3 | ± 2 dB |

- a. Peak-to-peak (p-p) deviation from nominal trace over frequency range
- b. Only for analyzers with Option 006

Required Equipment

| Description | Model Number or Part Number |
|--|-----------------------------|
| Power Meter | 436A/437B/438A |
| Power Sensor | 8482A |
| Cable, 50 Ω , 24-inch Type-N | part number 8120-4781 |
| Adapter, Type-N (f) to Type-N (f) | 11524A |
| Additional Equipment Required for Analyzers with Option 006 | |
| Power Sensor | 8482A |

Analyzer warmup time: 1 hour

Power Meter Calibration, Port 1 from 300 kHz to 3 GHz

1. Zero and calibrate the power meter.
2. Connect the equipment as shown in [Figure 1-19](#).

Figure 1-19 Setup for Power Meter Calibration on Port 1

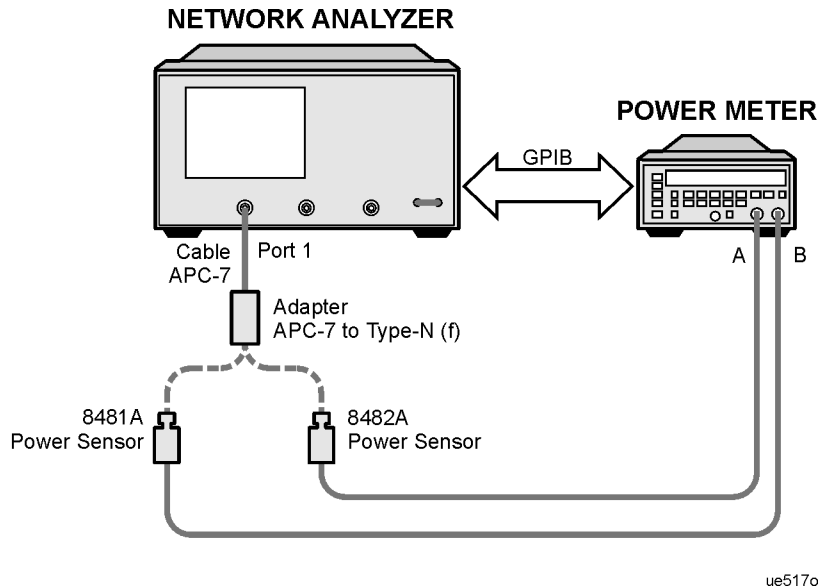

3. Press **Preset, Start, 300, k/m**.
4. *Only for analyzers with Option 006:* Press **Stop, 3, G/n**.
5. Press **Local, SYSTEM CONTROLLER**.
6. Press **SET ADDRESSES** and **POWER MTR** until the analyzer shows the correct power meter model.
7. Press **ADDRESS: P MTR/GPIB**. The default power meter GPIB address is 13. Make sure it is the same as your power meter GPIB address. Otherwise, use the analyzer front panel keypad to enter the correct GPIB address for your power meter.

8. Press **Sweep Setup**, **NUMBER of POINTS**, **51**, **x1**.
9. Press **Power**, **PWR RANGE MAN** to turn the auto power range off.

NOTE

The analyzer displays the **PRM** annotation, indicating that the analyzer power range is set to **MANUAL**.

10. Press **PORT POWER** to uncouple the port output power.
11. Press **Cal**, **PWRMTR CAL**.
12. Press **LOSS/SENSR LISTS**, **CAL FACTOR SENSOR A**. Refer to the back of the power sensor to locate the different calibration factor values along with their corresponding frequencies.

NOTE

The analyzer's calibration factor sensor table can hold a maximum of 55 calibration factor data points.

The following softkeys are included in the sensor calibration factor entries menu:

| | |
|-------------------|--|
| SEGMENT | Press to select a point where you can use the front panel knob or entry keys to enter a value. |
| EDIT | Press to edit or change a previously entered value. |
| DELETE | Press to delete a point from the sensor calibration factor table. |
| ADD | Select this key to add a point into the sensor calibration factor table. |
| CLEAR LIST | Select this key to erase the entire sensor calibration factor table. |
| DONE | Select this key when done entering points to the sensor calibration factor table. |

Performance Tests

The following keystrokes are examples for entering the first two calibration factor data points for the 8482A power sensor (assuming CF% = 96.4 at 100 kHz and CF% = 98.4 at 300 kHz):

1. From the Sensor Calibration Factor Entries menu, press **ADD**.
2. Press **FREQUENCY, 100, k/m**. If you make an entry error, press ← and re-enter the correct value again.
3. Press **CAL FACTOR, 96.4, x1**.
4. Press **DONE** to terminate the first calibration factor data point entry.
5. To enter the second cal factor data point, press **ADD**.
6. Press **FREQUENCY, 300, k/m**.
7. Press **CAL FACTOR, 98.4, x1**.
8. To terminate the second calibration factor data point entry, press **DONE**.
9. Press **SEGMENT** and use the front panel knob to scroll through the sensor calibration factors table. Check to be sure all values are entered correctly. If you spot an error, use the front panel knob to point to the data point you want to modify and press **EDIT**.
10. Press the appropriate softkeys to create a power sensor calibration factors table.
11. Press **DONE** to exit the sensor calibration factor entries menu.
12. Press **RETURN, ONE SWEEP, TAKE CAL SWEEP** to start the power meter calibration.

Wait until the analyzer finishes the sweep, then continue with this procedure.

NOTE

The analyzer displays the **PC** annotation indicating the power meter calibration is done and the error correction is active.

Port 3 Input Frequency Response from 300 kHz to 3 GHz

1. Connect the equipment as shown in [Figure 1-20](#).

Figure 1-20 Port 3 Input Frequency Response Test Setup

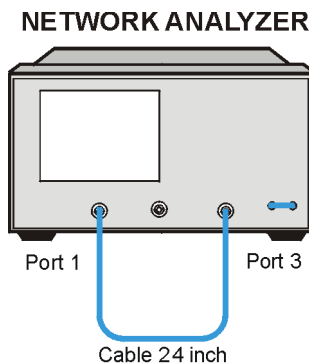

ue515c

2. Press **Meas**, **INPUT PORTS**, **B**.
3. Press **Scale Ref**, **SCALE/DIV**, **1**, **x1**.
4. Press **Marker**, **MARKER 1**, **Marker Search**, **SEARCH:MIN** to put marker 1 at the minimum magnitude location of the trace.
5. Press **Marker**, **Marker 2**, **Marker Search**, **SEARCH:MAX** to put at the maximum magnitude location of the trace.
6. Write the marker 1 or marker 2 value that appears on the analyzer display, whichever has the larger absolute magnitude, on the performance test record.

**Port 2 Input Frequency Response, from 300 kHz to 3 GHz,
Reverse Direction**

1. Disconnect the RF cable from Port 3.
2. Connect the RF cable to Port 2 as shown in [Figure 1-21](#).

Figure 1-21 Port 2 Input Frequency Response

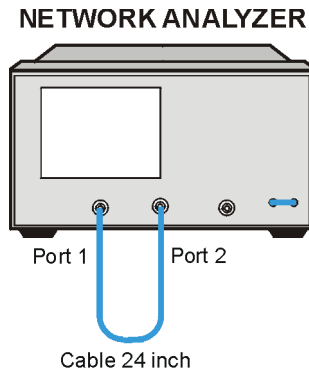

ue518c

3. Press **Meas**, **SELECT PORTS [1-2]**.
4. Press **Marker Fctn**, **MARKER MODE MENU**, **STATS ON**.
5. Read the peak-to-peak (p-p) value.

NOTE

The deviation between the minimum dB value and the maximum dB value over the frequency range is the peak-to-peak measurement for this test.

6. Write the peak-to-peak value on the performance test record.
7. Press **Marker Fctn**, **MARKER MODE MENU**, **STATS OFF**.
8. Press **Seq**, **TTL I/O**, **TTL OUT**, **TESTSET I/O REV**, 7, x1.

Power Meter Calibration on Port 3, from 300 kHz to 3 GHz

1. Connect the equipment as shown in [Figure 1-22](#).

Figure 1-22 Setup for Power Meter Calibration on Port 3
NETWORK ANALYZER

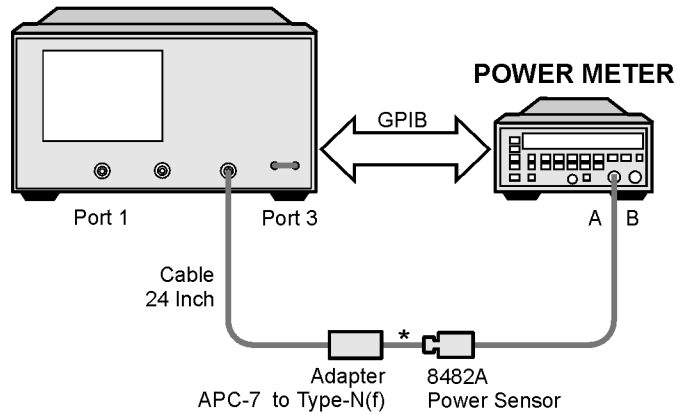

* Direct Connection

ue519o

2. Press **Meas, INPUT PORTS, TESTPORT 3**.
3. Press **Cal, PWRMTR CAL. ONE SWEEP, TAKE CAL SWEEP** to start the power meter calibration for Port 3.

4. When the analyzer displays the message `POWER METER CALIBRATION IS DONE`, connect the equipment as shown in [Figure 1-23](#).

Figure 1-23 Port 1 Input Frequency Response Test Setup

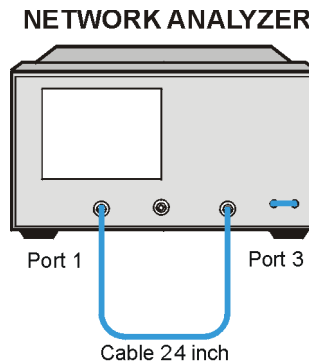

ue515c

Port 1 Input Frequency Response from 300 kHz to 3 GHz

1. Press **Meas**, **INPUT PORTS**, **A**.
2. Press **Marker**, **MARKER 1**, **Marker Search**, **SEARCH:MIN**.
3. Press **Marker**, **Marker 2**, **Marker Search**, **SEARCH:MAX**.
4. Write the marker 1 or marker 2 reading, whichever has the larger absolute magnitude, on the performance test record.

Port 2 Input Frequency Response from 300 kHz to 3 GHz, Forward Direction

1. Disconnect the RF cable from Port 1.
2. Connect the RF cable to Port 2.

Figure 1-24 Port 2 Input Frequency Response, 300 kHz to 3 GHz

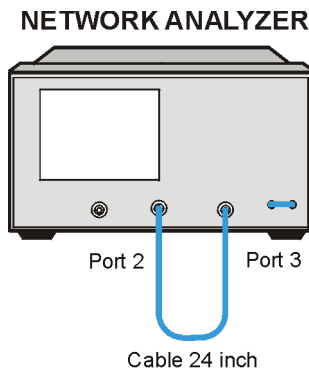

ue520c

3. Press **Meas**, **SELECT PORTS [2-3]**.
4. Press **Marker Fctn**, **MARKER MODE MENU**, **STATS ON**.
5. Read the peak-to-peak (p-p) value.

NOTE

The deviation between the minimum dB value and the maximum dB value over the frequency range is the peak-to-peak measurement for this test.

6. Write the peak-to-peak value on the performance test record.
7. Press **Marker Fctn**, **MARKER MODE MENU**, **STATS OFF**.
8. Press **Meas**, **SELECT PORTS [1-3]**.
9. If your analyzer does not have Option 006, this completes the procedure. If you have Option 006 in your analyzer, continue with the following sections.

Power Meter Calibration for Port 3 from 3 GHz to 6 GHz

1. Replace the power sensor with the 8481A, then set up the power meter as follows:
 - If the power meter is an 438A, press LCL.
 - If the power meter is an 437B, press PRESET/LOCAL.
 - If the power meter is an 436A, cycle the line power.
2. Connect the equipment as shown in [Figure 1-25](#).

Figure 1-25 Setup for Power Meter Calibration on Port 3

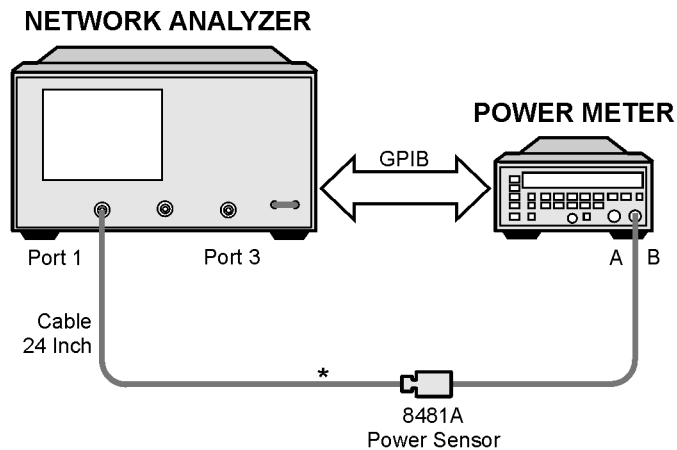

* Direct Connection

3. Press **Start, 3, G/n, Stop, 6, G/n**.
4. Press **Cal, PWRMTR CAL**.
5. Press **LOSS/SENSR LISTS, CAL FACTOR SENSOR B**. Refer to [“Power Meter Calibration, Port 1 from 300 kHz to 3 GHz”](#) on page 1-54 to build a calibration factor sensor table for the 8481A power sensor.
6. Press **DONE** to exit the sensor calibration factor entries menu.
7. To select the 8481A power sensor, press **USE SENSOR B**.

8. Press **RETURN, TAKE CAL SWEEP** to start the power meter calibration.

Port 1 Input Frequency Response from 3 GHz to 6 GHz

1. When the analyzer finishes the calibration sweep, connect the equipment as shown in [Figure 1-26](#).

Figure 1-26

Setup for Port 1 Input Frequency Response

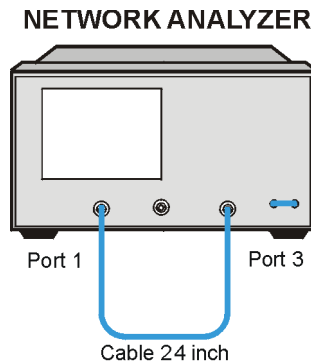

ue515c

2. Press **Meas, INPUT PORTS, A**.
3. Press **Marker, MARKER 1, Marker Search, SEARCH:MIN** to put marker 1 at the minimum magnitude location of the trace.
4. Press **Marker, MARKER 2, Marker Search, SEARCH:MAX** to put marker 2 at the maximum magnitude location of the trace.
5. Write the marker 1 or marker 2 reading, whichever has the largest absolute magnitude, on the performance test record.

**Port 2 Input Frequency Response from 3 GHz to 6 GHz,
Forward Direction**

1. Disconnect the RF cable from Port 1.
2. Connect the RF cable to Port 2.

Figure 1-27 Port 2 Input Frequency Response

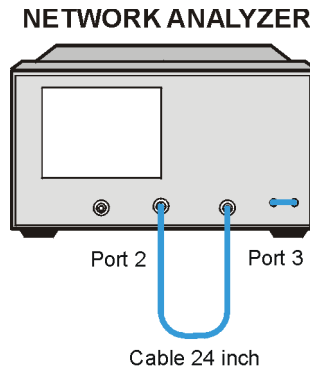

ue520c

3. Press **Meas, SELECT PORTS [2-3]**.
4. Press **Marker Fctn, MARKER MODE MENU, STATS ON**.
5. Read the peak-to-peak (p-p) value.

NOTE

The deviation between the minimum dB value and the maximum dB value over the frequency range is the peak-to-peak measurement for this test.

6. Write the peak-to-peak value on the performance test record.
7. Press **Marker Fctn, MARKER MODE MENU, STATS OFF**.
8. Press **Meas, SELECT PORTS [1-3]**.

Power Meter Calibration, Port 1 from 3 GHz to 6 GHz

1. Connect the equipment as shown in [Figure 1-28](#).

Figure 1-28

Setup for Power Meter Calibration on Port 1 NETWORK ANALYZER

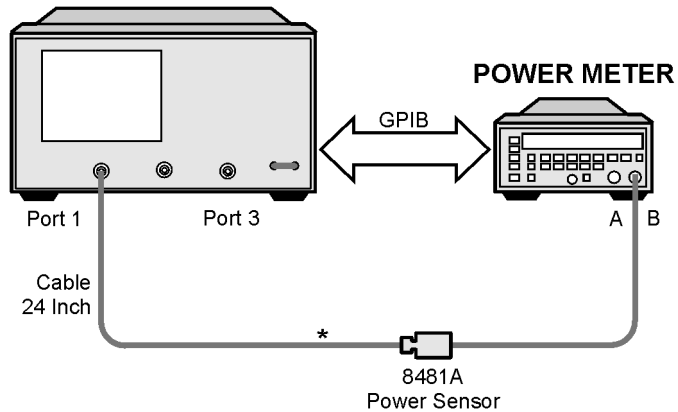

* Direct Connection

ue522o

2. Press **Meas**, **INPUT PORTS**, **TESTPORT 1**.
3. Press **Cal**, **PWRMTR**, **ONE SWEEP**, **TAKE CAL SWEEP** to start the power meter calibration for Port 1.

Port 3 Input Frequency Response from 3 GHz to 6 GHz

1. When the analyzer displays the message `POWER METER CALIBRATION SWEEP DONE`, connect the equipment as shown in Figure 1-29.

Figure 1-29

Port 3 Input Frequency Response Test Setup

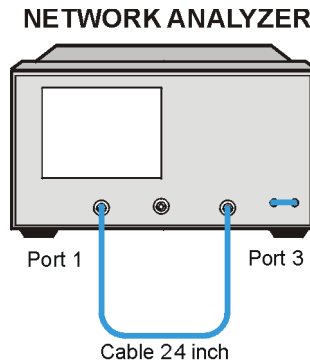

ue515c

2. Press **Meas**, **INPUT PORTS**, **B**.
3. Press **Marker**, **MARKER 1**, **Marker Search**, **SEARCH:MIN** to put marker 1 at the minimum magnitude location of the trace.
4. Press **Marker**, **MARKER 2**, **Marker Search**, **SEARCH:MAX** to put marker 2 at the maximum magnitude location of the trace.
5. Write the marker 1 or marker 2 reading, whichever has the largest absolute magnitude, on the performance test record.

**Port 2 Input Frequency Response from 3 GHz to 6 GHz,
Reverse Direction**

1. Disconnect the RF cable from Port 3.
2. Connect the RF cable to Port 2 as shown in [Figure 1-30](#).

Figure 1-30 Port 2 Input Frequency Response, Reverse Direction

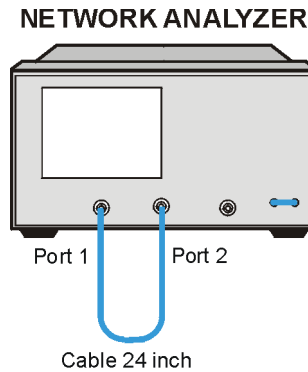

ue518c

3. Press **Meas, SELECT PORTS [1-2]**.
4. Press **Marker Fctn, MARKER MODE MENU, STATS ON**.
5. Read the peak-to-peak (p-p) value.

NOTE

The deviation between the minimum dB value and the maximum dB value over the frequency range is the peak-to-peak measurement for this test.

6. Write the peak-to-peak value on the performance test record.
7. Press **Marker Fctn, MARKER MODE MENU, STATS OFF**.
8. Press **Meas, SELECT PORTS [1-3]**.

In Case of Difficulty

1. Be sure you have used the correct power sensor for the frequency range.
2. Verify the calibration factors you have entered for the power sensors are correct.
3. Repeat this test with a known good through cable.

8. Test Port Crosstalk

Specifications

| Frequency Range | Crosstalk ^a |
|-----------------------------|------------------------|
| 300 kHz to 3 GHz | < -100 dB |
| 3 GHz to 6 GHz ^b | < -87 dB |

- a. Measurement conditions: 25 ± 5 °C; normalize to a through; measured with two shorts (or shielded open) 10 Hz IF BW; averaging factor 8; alternate model; source power at +10 dBm
- b. Only for analyzers with Option 006

Required Equipment

| Description | Model Number or Part Number |
|-----------------------------------|-----------------------------|
| Calibration Kit, 50Ω, Type-N | 85032B |
| Adapter, Type-N (m) to Type-N (m) | part number 1250-1475 |
| Cable, 50Ω, Type-N, 24-inch | part number 8120-4781 |

Analyzer warmup time: 1 hour

Normalization from 300 kHz to 3 GHz

1. Connect the 24-inch cable between Port 1 and Port 3 as shown in [Figure 1-31](#). Use the appropriate cable for your analyzer (50Ω or 75Ω).

Figure 1-31 Crosstalk Baseline Measurement Setup

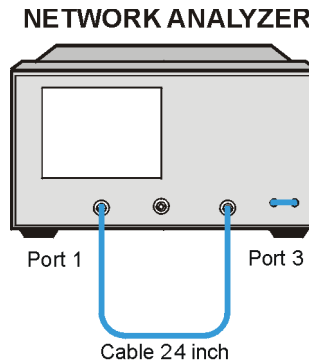

ue515c

2. Press **Preset, Cal, MORE, ALTERNATE A and B.**
3. Press **Start, 300, k/m, Stop, 3, G/n.**
4. Press **Sweep Setup, NUMBER of POINTS, 101, x1, Power, 10, x1.**
5. Press **Avg, IF BW, 10, x1, AVERAGING FACTOR, 8, x1, AVERAGING:ON.**
6. Press **Meas, Trans: FWD S31 (B/R).**
7. Press **Sweep Setup, TRIGGER MENU, NUMBER of GROUPS, 8, x1.** Wait for the sweeps to finish as indicated by the **H1d** notation on the left side of the display.
8. Press **Display, Data → MEMORY, DATA/MEM.**
9. Press **Chan 2, Avg, AVERAGING FACTOR, AVERAGING:ON, 8, x1, Meas, Trans:REV S13 (A/R).**
10. Press **Sweep Setup, TRIGGER MENU, NUMBER of GROUPS, 8, x1.** Wait for the sweeps to finish as indicated by the **H1d** notation on the left side of the display.
11. Press **Display, Data → MEMORY, DATA/MEM.**
12. Press **Scale Ref, SCALE/DIV, 5, x1, REFERENCE VALUE, -100, x1.**

13. Press Chan 1, Scale Ref, SCALE/DIV, 5, x1, REFERENCE VALUE, -100, x1.

Port Crosstalk (Port 1 and Port 3)

1. Connect the equipment as shown in Figure 1-32.

Figure 1-32

Port Crosstalk Test Setup

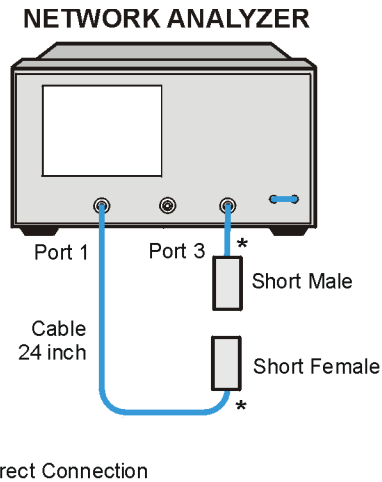

ue523o

2. Press Preset, Power, 10, x1.
3. Press Avg, IF BW, 10, x1.

Crosstalk to Port 3 from 300 kHz to 3 GHz

1. Press Start, 300, k/m, Stop, 3, G/n.
2. Press Meas, Trans: FWD S31 (B/R).
3. Press Scale Ref, REFERENCE VALUE, -100, x1.
4. Press Sweep Setup, TRIGGER MENU, SINGLE.
5. Wait until the trace has settled.
6. Press Marker Search, SEARCH:MAX.
7. Write the marker value that appears on the analyzer display on the performance test record.

Crosstalk to Port 1 from 300 kHz to 3 GHz

1. Press **Meas, Trans: REV S13 (A/R)**.
2. Press **Sweep Setup, TRIGGER MENU, SINGLE**.
3. Wait until the trace has settled.
4. Press **Marker Fctn, MARKER SEARCH, SEARCH:MAX**.
5. Write the marker value that appears on the analyzer display on the performance test record.
6. If your analyzer does not have Option 006, proceed to [“Port Crosstalk \(Port 2 and Port 3\)” on page 1-74](#). If you have Option 006 in your analyzer, continue with the following sections.

Crosstalk to Port 1 from 3 GHz to 6 GHz

1. Press **Start, 3, G/n, Stop, 6, G/n**.
2. Press **Sweep Setup, TRIGGER MENU, SINGLE**.
3. Wait until the trace has settled.
4. Press **Marker Fctn, MARKER SEARCH, SEARCH:MAX**.
5. Write the marker value that appears on the analyzer display on the performance test record.

Crosstalk to Port 3 from 3 GHz to 6 GHz

1. Press **Meas, TRANS:FWD S31 (B/R)**.
2. Press **Sweep Setup, TRIGGER MENU, SINGLE**.
3. Wait until the trace has settled.
4. Press **Marker Fctn, MARKER SEARCH, SEARCH:MAX**.
5. Write the marker value that appears on the analyzer display on the performance test record.

Normalize from 300 kHz to 3 GHz

1. Connect the 24-inch cable between Port 2 and Port 3 as shown in [Figure 1-33](#). Use the appropriate cable for your analyzer (50Ω or 75Ω).

Figure 1-33 Crosstalk Baseline Measurement

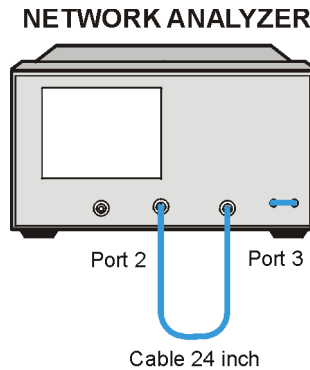

2. Press **Preset, Cal, MORE, ALTERNATE A and B.**
3. Press **Start, 300, k/m, Stop, 3, G/n.**
4. Press **Sweep Setup, NUMBER of POINTS, 101, x1, Power, 10, x1.**
5. Press **Avg, IF BW, 10, x1, AVERAGING FACTOR, 8, x1, AVERAGING: ON.**
6. Press **Meas, Select Ports [2–3], Trans: FWD S32 (B/R).**
7. Press **Sweep Setup, TRIGGER MENU, NUMBER of GROUPS, 8, x1.** Wait for the sweeps to finish as indicated by the **H1d** notation on the left side of the display.
8. Press **Display, DATA → MEMORY, DATA/MEM.**
9. Press **Chan 2, Avg, AVERAGING FACTOR, 8, x1, Meas, Trans: REV S23 (A/R).**
10. Press **Sweep Setup, TRIGGER MENU, NUMBER OF GROUPS, 8, x1.** Wait for the sweeps to finish as indicated by the **H1d** notation on the left side of the display.
11. Press **Display, DATA → MEMORY, DATA/MEM.**
12. Press **Scale Ref, SCALE/DIV, 5, x1, REFERENCE VALUE, –100, x1.**

System Verification and Performance Tests
Performance Tests

13. Press Chan 1, Scale Ref, SCALE/DIV, 5, x1, REFERENCE VALUE, -100, x1.

Port Crosstalk (Port 2 and Port 3)

1. Connect the equipment shown in [Figure 1-34](#).

Figure 1-34 Port Crosstalk Setup for Port 2 and Port 3

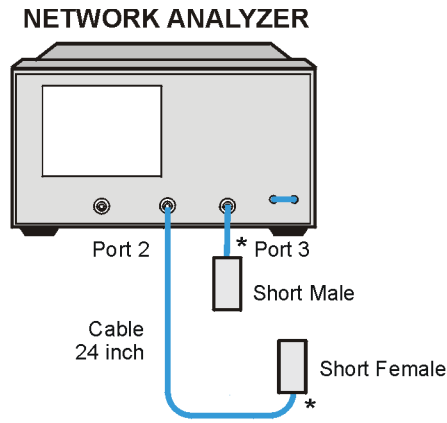

* Direct Connection

ue524o

2. Press **Preset, Power, 10, x1**.
3. Press **Avg, IF BW, 10, x1**.

Crosstalk to Port 3 from 300 kHz to 3 GHz

1. Press **Start, 300, k/m, Stop, 3, G/n**.
2. Press **Meas, Select Ports [2-3], Trans: FWD S32 (B/R)**.
3. Press **Scale Ref, REFERENCE VALUE, -100, x1**.
4. Press **Sweep Setup, TRIGGER MENU, SINGLE**.
5. Wait until the trace has settled.
6. Press **Marker Fctn, MARKER SEARCH, SEARCH:MAX**.
7. Write the marker value that appears on the analyzer display on the performance test record.

Crosstalk to Port 2 from 300 kHz to 3 GHz

1. Press **Meas, Trans: FWD S23 (A/R)**.
2. Press **Sweep Setup, TRIGGER MENU, SINGLE**.
3. Wait until the trace has settled.
4. Press **Marker Fctn, MARKER SEARCH, SEARCH:MAX**.
5. Write the marker value that appears on the analyzer display on the performance test record.
6. If your analyzer does not have Option 006, this completes the port crosstalk (Port 2 and Port 3) section. If you have Option 006 in your analyzer, continue with the following sections.

Crosstalk to Port 2 from 3 GHz to 6 GHz

1. Press **Start, 3, G/n, Stop, 6, G/n**.
2. Press **Sweep Setup, TRIGGER MENU, SINGLE**.
3. Wait until the trace has settled.
4. Press **Marker Fctn, MARKER SEARCH, SEARCH:MAX**.
5. Write the marker value that appears on the analyzer display on the performance test record.

Crosstalk to Port 3 from 3 GHz to 6 GHz

1. Press **Meas, Trans: FWD S32 (A/R)**.
2. Press **Sweep Setup, TRIGGER MENU, SINGLE**.
3. Wait until the trace has settled.
4. Press **Marker Fctn, MARKER SEARCH, SEARCH:MAX**.
5. Write the marker value that appears on the analyzer display on the performance test record.

Normalize from 300 kHz to 3 GHz

1. Connect the 24-inch cable between Port 1 and Port 2 as shown in [Figure 1-35](#). Use the appropriate cable for your analyzer (50Ω or 75Ω).

Figure 1-35 Crosstalk Baseline Measurement

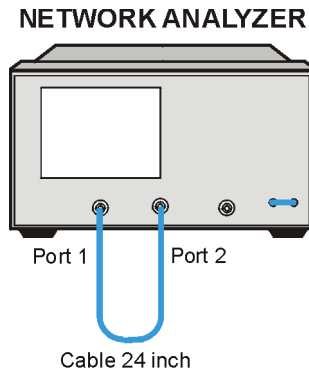

ue518c

2. Press **Preset, Cal, MORE, ALTERNATE A and B.**
3. Press **Start, 300, k/m, Stop, 3, G/n.**
4. Press **Sweep Setup, NUMBER of POINTS, 101, x1, Power, 10, x1.**
5. Press **Avg, IF BW, 10, x1, AVERAGING FACTOR, 8, x1, AVERAGING: ON.**
6. Press **Meas, Select Ports [1–2], Trans: FWD S21 (B/R).**
7. Press **Sweep Setup, TRIGGER MENU, NUMBER of GROUPS, 8, x1.** Wait for the sweeps to finish as indicated by the **H1d** notation on the left side of the display.
8. Press **Display, DATA → MEMORY, DATA/MEM.**
9. Press **Chan 2, Avg, AVERAGING FACTOR, AVERAGING:ON, 8, x1, Meas, Trans: REV S12 (A/R).**
10. Press **Sweep Setup, TRIGGER MENU, NUMBER OF GROUPS, 8, x1.** Wait for the sweeps to finish as indicated by the **H1d** notation on the left side of the display.
11. Press **Display, DATA → MEMORY, DATA/MEM.**

12. Press **Scale Ref**, **SCALE/DIV**, **5**, **x1**, **REFERENCE VALUE**, **-100**, **x1**.
13. Press **Chan 1**, **Scale Ref**, **SCALE/DIV**, **5**, **x1**, **REFERENCE VALUE**, **-100**, **x1**.

Port Crosstalk (Port 1 and Port 2)

1. Connect the equipment as shown in [Figure 1-36](#).

Figure 1-36 Port Crosstalk Setup, Port 1 and Port 2

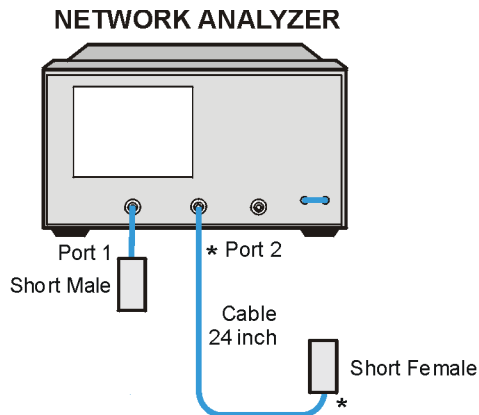

* Direct Connection

ue525c

2. Press **Preset**, **Power**, **10**, **x1**.
3. Press **Avg**, **IF BW**, **10**, **x1**.

Crosstalk to Port 2 from 300 kHz to 3 GHz

1. Press **Start**, **300**, **k/m**, **Stop**, **3**, **G/n**.
2. Press **Meas**, **Select Ports** [1–2], **Trans: FWD S21 (B/R)**.
3. Press **Scale Ref**, **REFERENCE VALUE**, **-100**, **x1**.
4. Press **Sweep Setup**, **TRIGGER MENU**, **SINGLE**.
5. Wait until the trace has settled.
6. Press **Marker Fctn**, **MARKER SEARCH**, **SEARCH:MAX**.
7. Write the marker value that appears on the analyzer display on the performance test record.

Crosstalk to Port 1 from 300 kHz to 3 GHz

1. Press **Meas, Trans: FWD S12 (A/R)**.
2. Press **Sweep Setup, TRIGGER MENU, SINGLE**.
3. Wait until the trace has settled.
4. Press **Marker Fctn, MARKER SEARCH, SEARCH:MAX**.
5. Write the marker value that appears on the analyzer display on the performance test record.
6. If your analyzer does not have Option 006, this completes the “[Port Crosstalk \(Port 1 and Port 2\)](#)” section. If you have Option 006 in your analyzer, continue with the following sections.

Crosstalk to Port 1 from 3 GHz to 6 GHz

1. Press **Start, 3, G/n, Stop, 6, G/n**.
2. Press **Sweep Setup, TRIGGER MENU, SINGLE**.
3. Wait until the trace has settled.
4. Press **Marker Fctn, MARKER SEARCH, SEARCH:MAX**.
5. Write the marker value that appears on the analyzer’s display on the performance test record.

Crosstalk to Port 2 from 3 GHz to 6 GHz

1. Press **Meas, Trans: FWD S21 (A/R)**.
2. Press **Sweep Setup, TRIGGER MENU, SINGLE**.
3. Wait until the trace has settled.
4. Press **Marker Fctn, MARKER SEARCH, SEARCH:MAX**.
5. Write the marker value that appears on the analyzer’s display on the performance test record.

In Case of Difficulty

1. Remove the instrument top cover. Using an 8 in-lb torque wrench, verify that all semirigid cables connected to the sampler and mixer assemblies are tight. In addition, tighten any loose screws on the sampler/mixer assemblies (A4/5/6) and the pulse generator assembly (A7).

2. Remove the instrument bottom cover. Refer to [Figure 1-37](#). Verify that all cables are tight.
3. Repeat all tests that failed.

Figure 1-37 Option H39 Assembly Bottom

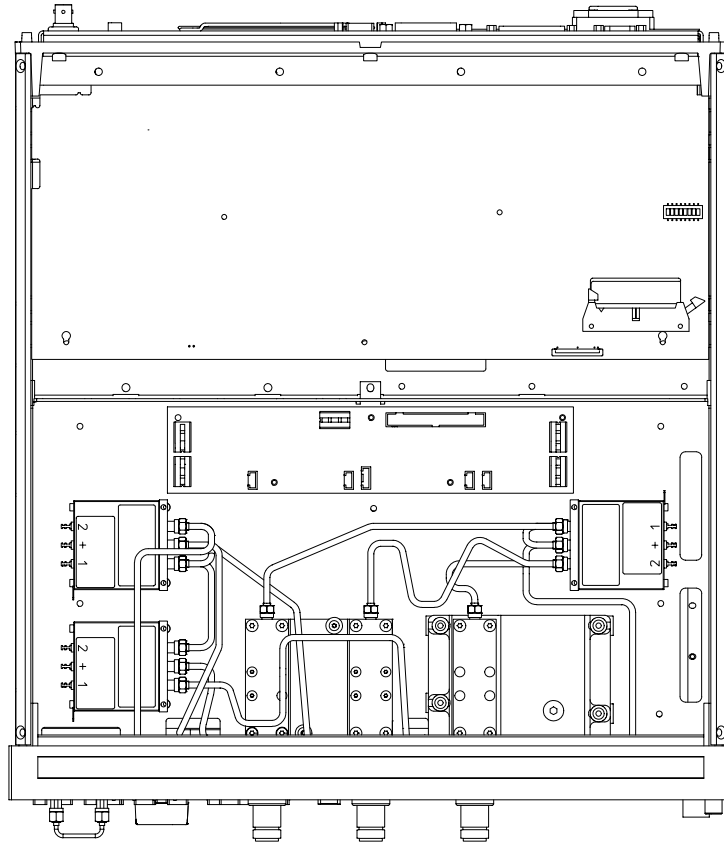

pg615h

9. Uncorrected Port Performance

Perform this procedure to verify the analyzer's uncorrected port characteristics.

Specifications

| Uncorrected ^a Error Terms | Frequency Range | | |
|---|-----------------------|---------------------|--------------------------------|
| | 300 kHz to 1.3 GHz | 1.3 GHz to 3 GHz | 3 GHz to 6 GHz ^b |
| Directivity | 35 dB | 30 dB | 20 dB |
| Source Match | 16 dB | 16 dB | 12 dB |
| Load Match | 18 dB | 16 dB | 14 dB |
| Transmission Tracking ^c | ±1.5 dB | ±1.5 dB | ±2.5 dB |
| Reflection Tracking ^c | ±1.5 dB | ±1.5 dB | ±2.5 dB |

- a. At 25 ± 5 °C, with less than 1 °C deviation from the measurement calibration temperature.
- b. Only for analyzers with Option 006.
- c. Port 2 is measured by peak-to-peak deviation from nominal trace across the frequency response.

Required Equipment

| Description | Model Number or Part Number |
|-----------------------------|-----------------------------|
| Calibration Kit, Type-N 50Ω | 85032B |
| Cable, 50Ω Type-N 24-inch | part number 8420-4781 |

Analyzer warmup time: 30 minutes

NOTE

The crosstalk calibration coefficients are omitted in this procedure. They are covered in the port crosstalk performance test.

Port 1 to Port 3 Full 2-Port Calibration

1. Connect the equipment as shown in [Figure 1-38](#).

Figure 1-38

First Full 2-Port Calibration Test Setup (Port 1 and Port 3)

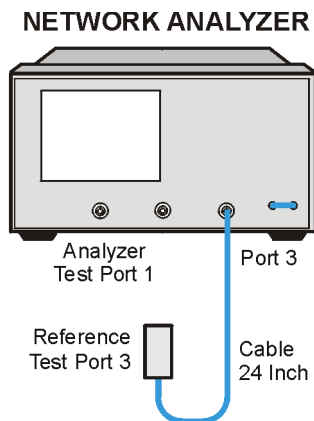

ue526o

2. Press **Preset, Start, 300, k/m**.
3. Press **Cal, CAL KIT, SELECT CAL KIT, CAL KIT:N 50Ω, RETURN, RETURN, CALIBRATE MENU, FULL 2-PORT**.
4. Press **ISOLATION, OMIT ISOLATION**.
5. Connect the open (supplied in the calibration kit) to Port 1.
6. Press **REFLECTION, FORWARD:OPEN, OPEN (F), DONE OPENS**.
7. Connect the short to Port 1.
8. Press **FORWARD: SHORT, SHORT (F) DONE SHORTS**.
9. Replace the short with the 50Ω termination (supplied in the calibration kit).
10. Press **FORWARD:LOAD**.
11. Connect the open to reference test port 3.
12. Press **REVERSE:OPEN, OPEN (M), DONE OPENS**.
13. Connect the short to reference test port 3.
14. Press **REVERSE: SHORT, SHORT (M), DONE SHORTS**.

System Verification and Performance Tests

Performance Tests

15. Connect the 50 Ω termination to reference test port 3.
16. Press **REVERSE: LOAD**.
17. When the analyzer displays **PRESS 'DONE' IF FINISHED WITH STD(s)**, press **STANDARDS DONE**.

Wait for the message **COMPUTING CAL COEFFICIENTS** to disappear from the analyzer display before proceeding to the next step.

18. Connect the equipment as shown in [Figure 1-39](#).

Figure 1-39 Transmission Calibration Test Setup (Port 1 to Port 3)

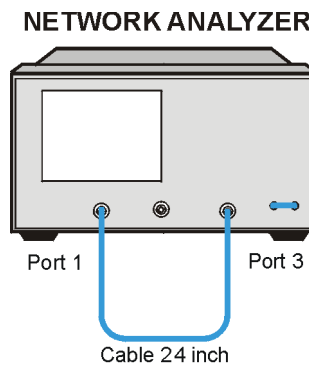

ue515c

19. Press **TRANSMISSION, DO BOTH FWD + REV**.
20. Press **DONE 2-PORT CAL**.

Directivity (Forward) Calibration Coefficient

1. Press **System, SERVICE MENU, TESTS, 32, x1, EXECUTE TEST**.
2. When the analyzer finishes the test, press **Scale Ref, AUTO SCALE, Marker**.
3. Using the front panel knob, locate the maximum value of the data trace for the 300 kHz to 1.3 GHz frequency range.
4. Write the maximum value on the performance test record.
5. Repeat the previous two steps for the other frequency range(s) listed on the performance test record.

Source Match (Forward) Calibration Coefficient

1. Press **System, SERVICE MENU, TESTS, 33, x1, EXECUTE TEST**.
2. When the analyzer finishes the test, press **Scale Ref, AUTO SCALE, Marker**.
3. Using the front panel knob, locate the maximum value of the data trace for the 300 kHz to 1.3 GHz frequency range.
4. Write the maximum value on the performance test record.
5. Repeat the previous two steps for the other frequency range(s) listed on the performance test record.

Reflection Tracking (Forward) Calibration Coefficient

1. Press **System, SERVICE MENU, TESTS, 34, x1, EXECUTE TEST**.
2. When the analyzer finishes the test, press **Scale Ref, AUTO SCALE, Marker**.
3. Using the front panel knob, locate the maximum value of the data trace for the 300 kHz to 1.3 GHz frequency range.
4. Write the maximum value on the performance test record.
5. Repeat the previous two steps for the other frequency range(s) listed on the performance test record.

Load Match (Reverse) Calibration Coefficient

1. Press **System, SERVICE MENU, TESTS, 42, x1, EXECUTE TEST**.
2. When the analyzer finishes the test, press **Scale Ref, AUTO SCALE, Marker**.
3. Using the front panel knob, locate the maximum value of the data trace for the 300 kHz to 1.3 GHz frequency range.
4. Write the maximum value on the performance test record.
5. Repeat the previous two steps for the other frequency range(s) listed on the performance test record.

Transmission Tracking (Reverse) Calibration Coefficient

1. Press **System**, **SERVICE MENU**, **TESTS**, **43**, **x1**, **EXECUTE TEST**.
2. When the analyzer finishes the test, press **Scale Ref**, **AUTO SCALE**, **Marker**.
3. Using the front panel knob, locate the maximum value of the data trace for the 300 kHz to 1.3 GHz frequency range.
4. Write the maximum value on the performance test record.
5. Repeat the previous two steps for the other frequency range(s) listed on the performance test record.

Port 1 to Port 3 Second Full 2-Port Calibration

1. Connect the equipment as shown in [Figure 1-40](#).

Figure 1-40

Second Full 2-Port Calibration Test Setup (Port 1 to Port 3)

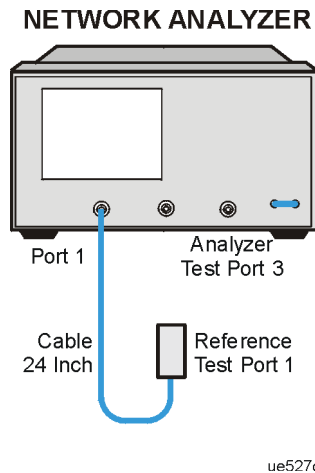

2. Press **Preset**, **Start**, **300**, **k/m**.
3. Press **Cal**, **CAL KIT**, **SELECT CAL KIT**, **CAL KIT:N 50Ω**, **RETURN**, **RETURN**, **CALIBRATE MENU**, **FULL 2-PORT**.
4. Press **ISOLATION**, **OMIT ISOLATION**.
5. Connect the open (supplied in the calibration kit) to reference test port 1.
6. Press **REFLECTION**, **FORWARD:OPEN**, **OPEN (M)**, **DONE OPENS**.

7. Connect the short to reference test port 1.
8. Press **FORWARD: SHORT, SHORT (M) DONE SHORTS.**
9. Replace the short with the 50 Ω termination (supplied in the calibration kit).
10. Press **FORWARD:LOAD.**
11. Connect the open to Port 3.
12. Press **REVERSE:OPEN, OPEN (F), DONE OPENS.**
13. Connect the short to Port 3.
14. Press **REVERSE: SHORT, SHORT (F), DONE SHORTS.**
15. Connect the 50 Ω termination to Port 3.
16. Press **REVERSE: LOAD.**
17. When the analyzer displays **PRESS 'DONE' IF FINISHED WITH STD(S)**, press **STANDARDS DONE.**

Wait for the message **COMPUTING CAL COEFFICIENTS** to disappear from the analyzer display before proceeding to the next step.

18. Connect the equipment as shown in [Figure 1-41](#).

Figure 1-41 **Transmission Calibration Test Setup (Port 1 to Port 3)**

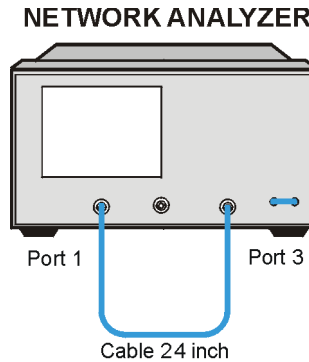

ue515c

19. Press **TRANSMISSION, DO BOTH FWD + REV.**

20. Press **DONE 2-PORT CAL.**

Load Match (Forward) Calibration Coefficient

1. Press **System, SERVICE MENU, TESTS, 36, x1, EXECUTE TEST.**
2. When the test is done, press **Scale Ref, AUTO SCALE, Marker, MARKER 1.**
3. Using the front panel knob, locate the maximum value of the data trace for the 300 kHz to 1.3 GHz frequency range.
4. Write the maximum value on the performance test record.
5. Repeat the previous two steps for the other frequency range(s) listed on the performance test record.

Directivity (Reverse) Calibration Coefficient

1. Press **System**, **SERVICE MENU**, **TESTS**, **38**, **x1**, **EXECUTE TEST**.
2. When the test is done, press **Scale Ref**, **AUTO SCALE**, **Marker**, **MARKER 1**.
3. Using the front panel knob, locate the maximum value of the data trace for the 300 kHz to 1.3 GHz frequency range.
4. Write the maximum value on the performance test record.
5. Repeat the previous two steps for the other frequency range(s) listed on the performance test record.

Source Match (Reverse) Calibration Coefficient

1. Press **System**, **SERVICE MENU**, **TESTS**, **39**, **x1**, **EXECUTE TEST**.
2. When the test is done, press **Scale Ref**, **AUTO SCALE**, **Marker**, **MARKER 1**.
3. Using the front panel knob, locate the maximum value of the data trace for the 300 kHz to 1.3 GHz frequency range.
4. Write the maximum value on the performance test record.
5. Repeat the previous two steps for the other frequency range(s) listed on the performance test record.

Reflection Tracking (Reverse) Calibration Coefficient

1. Press **System**, **SERVICE MENU**, **TESTS**, **40**, **x1**, **EXECUTE TEST**.
2. When the test is done, press **Scale Ref**, **AUTO SCALE**, **Marker**, **MARKER 1**.
3. Using the front panel knob, locate the maximum value of the data trace for the 300 kHz to 1.3 GHz frequency range.
4. Write the maximum value on the performance test record.
5. Repeat the previous two steps for the other frequency range(s) listed on the performance test record.

Transmission Tracking (Forward) Calibration Coefficient

1. Press **System**, **SERVICE MENU**, **TESTS**, **37**, **x1**, **EXECUTE TEST**.
2. When the analyzer finishes the test, press **Scale Ref**, **AUTO SCALE**, **Marker**.
3. Using the front panel knob, locate the maximum value of the data trace for the 300 kHz to 1.3 GHz frequency range.
4. Write the maximum value on the performance test record.
5. Repeat the previous two steps for the other frequency range(s) listed on the performance test record.

Port 2 to Port 3 Full 2-Port Calibration

1. Connect the equipment as shown in [Figure 1-42](#).

Figure 1-42

First Full 2-Port Calibration Test Setup (Port 2 and Port 3)

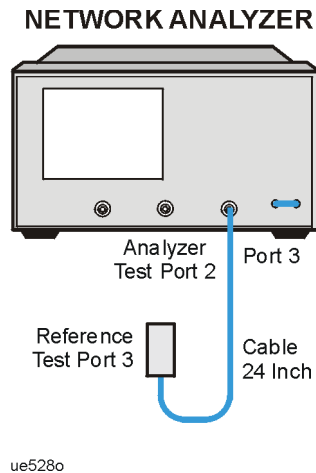

2. Press **Preset**, **Start**, **300**, **k/m**.
3. Press **Meas**, **SELECT PORTS** [2–3].
4. Press **Cal**, **CAL KIT**, **SELECT CAL KIT**, **CAL KIT:N 50Ω**, **RETURN**, **RETURN**, **CALIBRATE MENU**, **FULL 2-PORT**.
5. Press **ISOLATION**, **OMIT ISOLATION**.
6. Connect the open (supplied in the calibration kit) to Port 2.

7. Press **REFLECTION, FORWARD:OPEN, OPEN (F), DONE OPENS.**
8. Connect the short to Port 2.
9. Press **FORWARD: SHORT, SHORT (F) DONE SHORTS.**
10. Replace the short with the 50Ω termination (supplied in the calibration kit).
11. Press **FORWARD:LOAD.**
12. Connect the open to reference test port 3.
13. Press **REVERSE:OPEN, OPEN (M), DONE OPENS.**
14. Connect the short to reference test port 3.
15. Press **REVERSE: SHORT, SHORT (M), DONE SHORTS.**
16. Connect the 50Ω termination to reference test port 3.
17. Press **REVERSE: LOAD.**
18. When the analyzer displays **PRESS 'DONE' IF FINISHED WITH STD(s)**, press **STANDARDS DONE.**

Wait for the message **COMPUTING CAL COEFFICIENTS** to disappear from the analyzer's display before proceeding to the next step.
19. Connect the equipment as shown in [Figure 1-43](#).

Figure 1-43 Transmission Calibration Test Setup (Port 2 to Port 3)

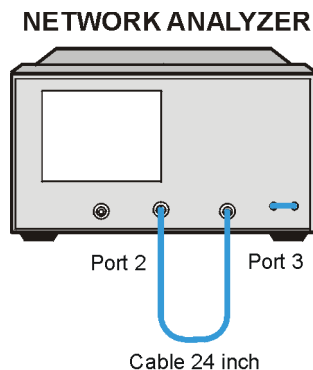

ue520c

20. Press **TRANSMISSION, DO BOTH FWD + REV.**
21. Press **DONE 2-PORT CAL.**

Performance Tests

Directivity (Forward) Calibration Coefficient

1. Press **System**, **SERVICE MENU**, **TESTS**, **32**, **x1**, **EXECUTE TEST**.
2. When the analyzer finishes the test, press **Scale Ref**, **AUTO SCALE**, **Marker**.
3. Using the front panel knob, locate the maximum value of the data trace for the 300 kHz to 1.3 GHz frequency range.
4. Write the maximum value on the performance test record.
5. Repeat the previous two steps for the other frequency range(s) listed on the performance test record.

Source Match (Forward) Calibration Coefficient

1. Press **System**, **SERVICE MENU**, **TESTS**, **33**, **x1**, **EXECUTE TEST**.
2. When the analyzer finishes the test, press **Scale Ref**, **AUTO SCALE**, **Marker**.
3. Using the front panel knob, locate the maximum value of the data trace for the 300 kHz to 1.3 GHz frequency range.
4. Write the maximum value on the performance test record.
5. Repeat the previous two steps for the other frequency range(s) listed on the performance test record.

Load Match (Reverse) Calibration Coefficient

1. Press **System**, **SERVICE MENU**, **TESTS**, **42**, **x1**, **EXECUTE TEST**.
2. When the analyzer finishes the test, press **Scale Ref**, **AUTO SCALE**, **Marker**.
3. Using the front panel knob, locate the minimum value of the data trace for the 300 kHz to 1.3 GHz frequency range.
4. Repeat the previous two steps for the other frequency range(s) listed on the performance test record.

Transmission Tracking (Reverse) Calibration Coefficient

1. Press **System**, **SERVICE MENU**, **TESTS**, **43**, **x1**, **EXECUTE TEST**.
2. When the analyzer finishes the test, press **Scale Ref**, **AUTO SCALE**, **Marker**.
3. Press **MARKER 2**. Using the front panel knob, locate the maximum value of the data trace for the 300 kHz to 1.3 GHz frequency range.
4. Press Δ **MENU MODE**, Δ **REF=1**. Write the value on the performance test record.
5. Repeat the previous two steps for the other frequency range(s) listed on the performance test record.
6. Press **MARKER**, **ALL OFF**.

Port 2 to Port 3 Second Full 2-Port Calibration

1. Connect the equipment as shown in [Figure 1-44](#).

Figure 1-44

Second Full 2-Port Calibration Test Setup (Port 2 to Port 3)

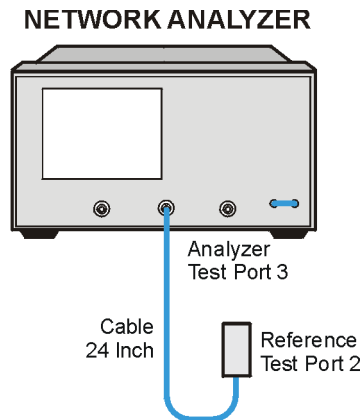

ue529o

2. Press **Preset**, **Start**, **300**, **k/m**.
3. Press **Meas**, **SELECT PORTS [2–3]**.

Performance Tests

4. Press **Cal, CAL KIT, SELECT CAL KIT, CAL KIT:N 50Ω, RETURN, RETURN, CALIBRATE MENU, FULL 2-PORT.**
5. Press **ISOLATION, OMIT ISOLATION.**
6. Connect the open (supplied in the calibration kit) to reference test port 2.
7. Press **REFLECTION, FORWARD:OPEN, OPEN (M), DONE OPENS.**
8. Connect the short to reference test port 2.
9. Press **FORWARD: SHORT, SHORT (M) DONE SHORTS.**
10. Replace the short with the 50Ω termination (supplied in the calibration kit).
11. Press **FORWARD:LOAD.**
12. Connect the open to Port 3.
13. Press **REVERSE:OPEN, OPEN (F), DONE OPENS.**
14. Connect the short to Port 3.
15. Press **REVERSE: SHORT, SHORT (F), DONE SHORTS.**
16. Connect the 50Ω termination to Port 3.
17. Press **REVERSE: LOAD.**
18. When the analyzer displays **PRESS 'DONE' IF FINISHED WITH STD(s)**, press **STANDARDS DONE.**

Wait for the message **COMPUTING CAL COEFFICIENTS** to disappear from the analyzer's display before proceeding to the next step.

19. Connect the equipment as shown in [Figure 1-45](#).

Figure 1-45 Transmission Calibration Test Setup (Port 2 to Port 3)

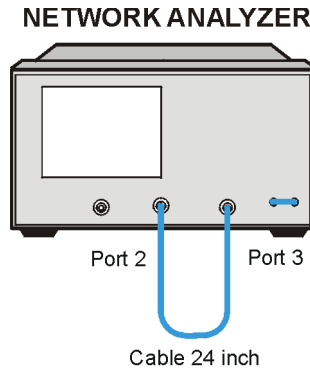

ue520c

20. Press **TRANSMISSION, DO BOTH FWD + REV.**

21. Press **DONE 2-PORT CAL.**

Load Match (Forward) Calibration Coefficient

1. Press **System, SERVICE MENU, TESTS, 36, x1, EXECUTE TEST.**
2. When the test is done, press **Scale Ref, AUTO SCALE, Marker, MARKER 1.**
3. Using the front panel knob, locate the maximum value of the data trace for the 300 kHz to 1.3 GHz frequency range.
4. Write the maximum value on the performance test record.
5. Repeat the previous two steps for the other frequency range(s) listed on the performance test record.

Directivity (Reverse) Calibration Coefficient

1. Press **System, SERVICE MENU, TESTS, 32, x1, EXECUTE TEST.**
2. When the test is done, press **Scale Ref, AUTO SCALE, Marker, MARKER 1.**

Performance Tests

3. Using the front panel knob, locate the maximum value of the data trace for the 300 kHz to 1.3 GHz frequency range.
4. Write the maximum value on the performance test record.
5. Repeat the previous two steps for the other frequency range(s) listed on the performance test record.

Source Match (Reverse) Calibration Coefficient

1. Press **System, SERVICE MENU, TESTS, 39, x1**. At the prompt, press **EXECUTE TEST**.
2. When the test is done, press **Scale Ref, AUTO SCALE, Marker, MARKER 1**.
3. Using the front panel knob, locate the maximum value of the data trace for the 300 kHz to 1.3 GHz frequency range.
4. Write the maximum value on the performance test record.
5. Repeat the previous two steps for the other frequency range(s) listed on the performance test record.

Reflection Tracking (Reverse) Calibration Coefficient

1. Press **System, SERVICE MENU, TESTS, 40, x1, EXECUTE TEST**.
2. When the test is done, press **Scale Ref, AUTO SCALE, Marker, MARKER 1**.
3. Using the front panel knob, locate the maximum value of the data trace for the 300 kHz to 1.3 GHz frequency range.
4. Write the maximum value on the performance test record.
5. Repeat the previous two steps for the other frequency range(s) listed on the performance test record.

Transmission Tracking (Forward) Calibration Coefficient

1. Press **System, SERVICE MENU, TESTS, 37, x1, EXECUTE TEST**.
2. When the analyzer completes the test, press **Scale Ref, AUTO SCALE, Marker, MARKER 1**.
3. Using the front panel knob, locate the minimum value of the data trace for the 300 kHz to 1.3 GHz frequency range.

4. Press **MARKER 2**.
5. Using the front panel knob, locate the maximum value of the data trace for the 300 kHz to 1.3 GHz frequency range.
6. Press Δ **MENU MODE**, Δ **REF=1**. Write the value on the performance test record.
7. Repeat steps 3 through 5 for the other frequency range(s) listed on the performance test record.
8. Press **Marker, All OFF**.

Port 1 to Port 2 Full 2-Port Calibration

1. Connect the equipment as shown in [Figure 1-46](#).

Figure 1-46

First Full 2-Port Calibration Test Setup (Port 1 and Port 2)

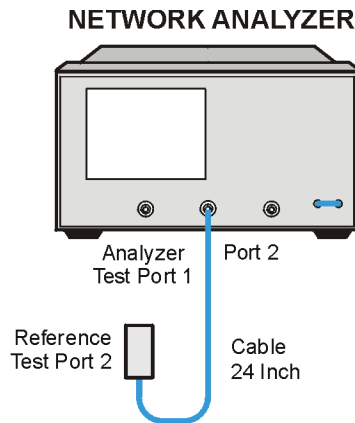

ue530o

2. Press **Preset, Start, 300, k/m**.
3. Press **Meas, SELECT PORTS [1-2]**.
4. Press **Cal, CAL KIT, SELECT CAL KIT, CAL KIT:N 50 Ω , RETURN, RETURN, CALIBRATE MENU, FULL 2-PORT**.
5. Press **ISOLATION, OMIT ISOLATION**.
6. Connect the open (supplied in the calibration kit) to Port 1.
7. Press **REFLECTION, FORWARD:OPEN, OPEN (F), DONE OPENS**.

System Verification and Performance Tests
Performance Tests

8. Connect the short to Port 1.
9. Press **FORWARD: SHORT, SHORT (F) DONE SHORTS.**
10. Replace the short with the 50 Ω termination (supplied in the calibration kit).
11. Press **FORWARD:LOAD.**
12. Connect the open to reference test port 2.
13. Press **REVERSE:OPEN, OPEN (M), DONE OPENS.**
14. Connect the short to reference test port 2.
15. Press **REVERSE: SHORT, SHORT (M), DONE SHORTS.**
16. Connect the 50 Ω termination to reference test port 2.
17. Press **REVERSE: LOAD.**
18. When the analyzer displays **PRESS 'DONE' IF FINISHED WITH STD(S)**, press **STANDARDS DONE.**

Wait for the message **COMPUTING CAL COEFFICIENTS** to disappear from the analyzer's display before proceeding to the next step.

19. Connect the equipment as shown in [Figure 1-47 on page 1-96](#).

Figure 1-47 Transmission Calibration Test Setup (Port 1 to Port 2)

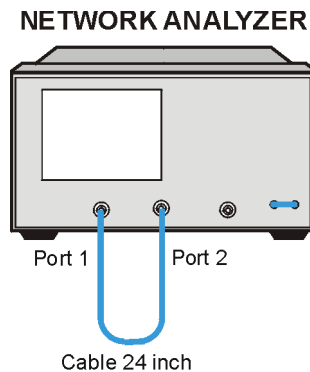

ue518c

20. Press **TRANSMISSION, DO BOTH FWD + REV.**
21. Press **DONE 2-PORT CAL.**

Directivity (Forward) Calibration Coefficient

1. Press **System, SERVICE, MENU, TESTS, 32, x1, EXECUTE TEST.**
2. When the analyzer finishes the test, press **Scale Ref, AUTO SCALE, Marker.**
3. Using the front panel knob, locate the maximum value of the data trace for the 300 kHz to 1.3 GHz frequency range.
4. Write the maximum value on the performance test record.
5. Repeat the previous two steps for the other frequency range(s) listed on the performance test record.

Source Match (Forward) Calibration Coefficient

1. Press **System, SERVICE MENU, TESTS, 33, x1, EXECUTE TEST.**
2. When the analyzer finishes the test, press **Scale Ref, AUTO SCALE, Marker.**
3. Using the front panel knob, locate the maximum value of the data trace for the 300 kHz to 1.3 GHz frequency range.
4. Write the maximum value on the performance test record.
5. Repeat the previous two steps for the other frequency range(s) listed on the performance test record.

Reflection Tracking (Forward) Calibration Coefficient

1. Press **System, SERVICE MENU, TESTS, 34, x1, EXECUTE TEST.**
2. When the analyzer finishes the test, press **Scale Ref, AUTO SCALE, Marker.**
3. Using the front panel knob, locate the maximum value of the data trace for the 300 kHz to 1.3 GHz frequency range.
4. Write the maximum value on the performance test record.
5. Repeat the previous two steps for the other frequency range(s) listed on the performance test record.

Load Match (Reverse) Calibration Coefficient

1. Press **System, SERVICE MENU, TESTS, 42, x1, EXECUTE TEST**.
2. When the analyzer finishes the test, press **Scale Ref, AUTO SCALE, Marker**.
3. Using the front panel knob, locate the maximum value of the data trace for the 300 kHz to 1.3 GHz frequency range.
4. Write the maximum value on the performance test record.
5. Repeat the previous two steps for the other frequency range(s) listed on the performance test record.

Transmission Tracking (Reverse) Calibration Coefficient

1. Press **System, SERVICE MENU, TESTS, 43, x1, EXECUTE TEST**.
2. When the analyzer finishes the test, press **Scale Ref, AUTO SCALE, Marker**. Using the front panel knob, locate the maximum value of the data trace for the 300 kHz to 1.3 GHz frequency range.
3. Press **MARKER 2**. Using the front panel knob, locate the maximum value of the data trace for the 300 kHz to 1.3 GHz frequency range.
4. Press **Δ MENU MODE, Δ REF=1**. Write the value on the performance test record.
5. Repeat the previous two steps for the other frequency range(s) listed on the performance test record.
6. Press **Marker, All OFF**.

Port 1 to Port 2 Second Full 2-Port Calibration

1. Connect the equipment as shown in [Figure 1-48](#).

Figure 1-48

Second Full 2-Port Calibration Test Setup (Port 1 to Port 2)

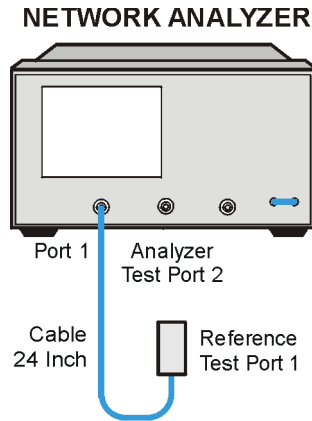

ue531c

2. Press **Preset, Start, 300, k/m**.
3. Press **Meas, SELECT PORTS [1-2]**.
4. Press **Cal, CAL KIT, SELECT CAL KIT, CAL KIT:N 50 Ω , RETURN, RETURN, CALIBRATE MENU, FULL 2-PORT**.
5. Press **ISOLATION, OMIT ISOLATION**.
6. Connect the open (supplied in the calibration kit) to reference test port 1.
7. Press **REFLECTION, FORWARD:OPEN, OPEN (M), DONE OPENS**.
8. Connect the short to reference test port 1.
9. Press **FORWARD: SHORT, SHORT (M) DONE SHORTS**.
10. Replace the short with the 50 Ω termination (supplied in the calibration kit).
11. Press **FORWARD:LOAD**.
12. Connect the open to Port 2.
13. Press **REVERSE:OPEN**.

System Verification and Performance Tests
Performance Tests

14. Connect the short to Port 2.
15. Press **REVERSE: SHORT, OPEN (F), DONE OPENS.**
16. Connect the 50 Ω termination to Port 2.
17. Press **REVERSE: LOAD, SHORT (F), DONE SHORTS.**
18. When the analyzer displays **PRESS 'DONE' IF FINISHED WITH STD(S)**, press **STANDARDS DONE.**

Wait for the message **COMPUTING CAL COEFFICIENTS** to disappear from the analyzer's display before proceeding to the next step.
19. Connect the equipment as shown in **Figure 1-49.**

Figure 1-49 Transmission Calibration Test Setup (Port 1 to Port 2)

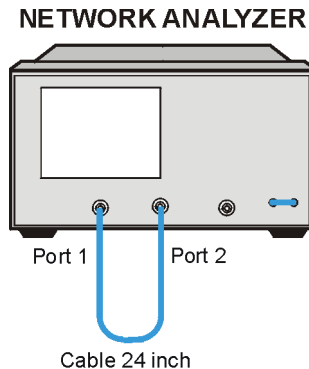

ue518c

20. Press **TRANSMISSION, DO BOTH FWD + REV.**
21. Press **DONE 2-PORT CAL.**

Load Match (Forward) Calibration Coefficient

1. Press **System, SERVICE MENU, TESTS, 36, x1, EXECUTE TEST**.
2. When the test is done, press **Scale Ref, AUTO SCALE, Marker, MARKER 1**.
3. Using the front panel knob, locate the maximum value of the data trace for the 300 kHz to 1.3 GHz frequency range.
4. Write the maximum value on the performance test record.
5. Repeat the previous two steps for the other frequency range(s) listed on the performance test record.

Directivity (Reverse) Calibration Coefficient

1. Press **System, SERVICE MENU, TESTS, 38, x1, EXECUTE TEST**.
2. When the test is done, press **Scale Ref, AUTO SCALE, Marker, MARKER 1**.
3. Using the front panel knob, locate the maximum value of the data trace for the 300 kHz to 1.3 GHz frequency range.
4. Write the maximum value on the performance test record.
5. Repeat the previous two steps for the other frequency range(s) listed on the performance test record.

Source Match (Reverse) Calibration Coefficient

1. Press **System, SERVICE MENU, TESTS, 39, x1**. At the prompt, press **EXECUTE TEST**.
2. When the test is done, press **Scale Ref, AUTO SCALE, Marker, MARKER 1**.
3. Using the front panel knob, locate the maximum value of the data trace for the 300 kHz to 1.3 GHz frequency range.
4. Write the maximum value on the performance test record.
5. Repeat the previous two steps for the other frequency range(s) listed on the performance test record.

Reflection Tracking (Reverse) Calibration Coefficient

1. Press **System, SERVICE MENU, TESTS, 40, x1, EXECUTE TEST.**
2. When the test is done, press **Scale Ref, AUTO SCALE, Marker, MARKER 1.**
3. Using the front panel knob, locate the minimum value of the data trace for the 300 kHz to 1.3 GHz frequency range.
4. Press **MARKER 2.**
5. Using the front panel knob, locate the maximum value of the data trace for the 300 kHz to 1.3 GHz frequency range.
6. Press **Δ MENU MODE, Δ REF=1.** Write the value on the performance test record.
7. Repeat the previous two steps for the other frequency range(s) listed on the performance test record.
8. Press **Marker, All OFF.**

Transmission Tracking (Forward) Calibration Coefficient

1. Press **System, SERVICE MENU, TESTS, 37, x1, EXECUTE TEST.**
2. When the analyzer finishes the test, press **Scale Ref, AUTO SCALE, Marker.**
3. Using the front panel knob, locate the minimum value of the data trace for the 300 kHz to 1.3 GHz frequency range.
4. Press **MARKER 2.**
5. Using the front panel knob, locate the maximum value of the data trace for the 300 kHz to 1.3 GHz frequency range.
6. Press **Δ MENU MODE, Δ REF=1.** Write the value on the performance test record.
7. Repeat the previous two steps for the other frequency range(s) listed on the performance test record.
8. Press **Marker, All OFF.**

In Case of Difficulty

1. Perform the “ADC Offset Correction Constants” procedure, located in standard documentation.
2. Repeat this performance test.
3. Suspect the A10 digital IF board assembly if the analyzer still fails the test.

10. System Trace Noise

Perform this test to measure the system trace noise at designated CW frequencies in both the A/R and B/R ratioed measurements.

Specifications

| Frequency Range | Ratio | System Trace Noise ^a (Magnitude) | System Trace Noise ^a (Phase) |
|----------------------|-------|--|--|
| IF Bandwidth = 10 Hz | | | |
| 300 kHz to 3 GHz | A/R | <0.001 dB rms | <0.006 ° rms |
| 300 kHz to 3 GHz | B/R | <0.001 dB rms | <0.006 ° rms |
| 3 GHz to 6 GHz | A/R | <0.002 dB rms | <0.0012 ° rms |
| 3 GHz to 6 GHz | B/R | <0.002 dB rms | <0.0012 ° rms |
| IF Bandwidth = 3 kHz | | | |
| 30 kHz to 3 GHz | A/R | <0.006 dB rms | <0.038 ° rms |
| 30 kHz to 3 GHz | B/R | <0.006 dB rms | <0.038 ° rms |
| 3 GHz to 6 GHz | A/R | <0.010 dB rms | <0.070 ° rms |
| 3 GHz to 6 GHz | B/R | <0.010 dB rms | <0.070 ° rms |

- a. Transmission measurement in CW mode with a through cable having 0 dB loss, the source set to +5 dBm, and no averaging.

Required Equipment

| Description | Model Number or Part Number |
|---|------------------------------------|
| Power Meter | 436A/437B/438A or E4418B/E4419B |
| Power Sensor | 8482A |
| Step Attenuator, 110 dB (See notes on the following page.) | 8496A Option 003, H18 |
| Adapter (2), APC-7 to Type-N (f) | 11525A |
| Cable, GPIB | 10833A |
| Calibration Kit, 7-mm, 50Ω | 85031B |
| Attenuator, 20 dB | 8492A Option 020 |
| Cable, APC-7, 50Ω | part number 8120-4781 |

Analyzer warmup time: 30 minutes

1. Connect the equipment as shown in [Figure 1-50](#).

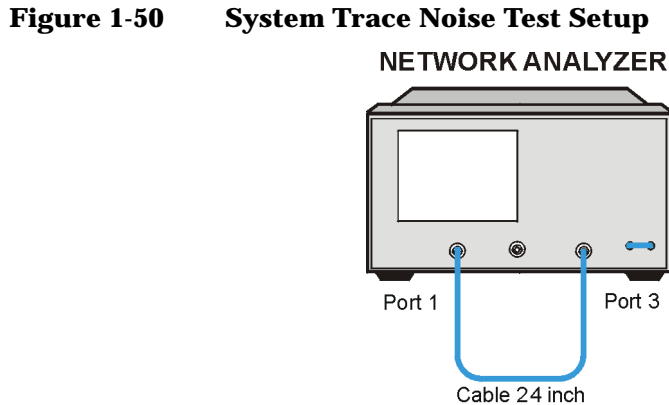

2. Press **Preset, 6, Power, 5, x1, Sweep Setup, NUMBER of POINTS, 51, x1**.
3. Press **Marker Fctn, MARKER MODE MENU, MKR STATS ON** to activate the instrument's statistics feature.
4. Press **Sweep Setup, CW FREQ, 3, G/n**.

A/R Trace Noise Magnitude IF BW = 10 Hz

1. Press **Avg, IF BW, 10, x1**.
2. Press **Meas, Trans:REV S13 (A/R)**.
3. Press **Sweep Setup, TRIGGER MENU, SINGLE**. Wait for the sweep to finish as indicated by the **Hld** notation on the left side of the display.
4. Press **Scale Ref, AUTO SCALE**.
5. Write the **s.dev** (standard deviation) value shown that appears on the analyzer display on the performance test record.

A/R Trace Noise Phase IF BW = 10 Hz

1. Press **Format, PHASE**.
2. Press **Sweep Setup, TRIGGER MENU, SINGLE**. Wait for the sweep to finish as indicated by the Hld notation on the left side of the display.
3. Press **Scale Ref, AUTO SCALE**.
4. Write the s.dev (standard deviation) value shown that appears on the analyzer display on the performance test record.

A/R Trace Noise Phase IF BW = 3 kHz

1. Press **Avg, IF BW, 3, k/m**.
2. Press **Sweep Setup, TRIGGER MENU, SINGLE**. Wait for the sweep to finish as indicated by the Hld notation on the left side of the display.
3. Press **Scale Ref, AUTO SCALE**.
4. Write the s.dev (standard deviation) value shown that appears on the analyzer display on the performance test record.

A/R Trace Noise Magnitude IF BW = 3 kHz

1. Press **Format, LOG MAG**.
2. Press **Sweep Setup, TRIGGER MENU, SINGLE**. Wait for the sweep to finish as indicated by the Hld notation on the left side of the display.
3. Press **Scale Ref, AUTO SCALE**.
4. Write the s.dev (standard deviation) value shown that appears on the analyzer display on the performance test record.

B/R Trace Noise Magnitude IF BW = 3 kHz

1. Press **Meas, Trans: FWD S31 (B/R), Sweep Setup, TRIGGER MENU, SINGLE**. Wait for the sweep to finish as indicated by the Hld notation on the left side of the display
2. Press **Scale Ref, AUTO SCALE**.
3. Write the s.dev (standard deviation) value shown that appears on the analyzer display on the performance test record.

B/R Trace Noise Phase IF BW = 3 kHz

1. Press **Format, PHASE, Sweep Setup, TRIGGER MENU, SINGLE**. Wait for the sweep to finish as indicated by the H1d notation on the left side of the display.
2. Press **Scale Ref, AUTO SCALE**.
3. Write the s.dev (standard deviation) value shown that appears on the analyzer display on the performance test record.

B/R Trace Noise Phase IF BW = 10 Hz

1. Press **Avg, IF BW, 10, x1, Sweep Setup, TRIGGER MENU, SINGLE**. Wait for the sweep to finish as indicated by the H1d notation on the left side of the display.
2. Press **Scale Ref, AUTO SCALE**.
3. Write the s.dev value that appears on the analyzer display on the performance test record.

B/R Trace Noise Magnitude IF BW = 10 Hz

1. Press **Format, LOG MAG, Sweep Setup, TRIGGER MENU, SINGLE**. Wait for the sweep to finish as indicated by the H1d notation on the left side of the display.
2. Press **Scale Ref, AUTO SCALE**.
3. Write the s.dev (standard deviation) value shown that appears on the analyzer display on the performance test record.

Option 006:

1. Press **Sweep Setup, CW FREQ, 6**.
2. Go back to [“A/R Trace Noise Magnitude IF BW = 10 Hz” on page 1-106](#) and perform this entire procedure again. Record all values in the performance test record under “Frequency 6 GHz.”

In Case of Difficulty

1. Perform the “ADC Offset Correction Constants” procedure, located in the standard documentation.
2. Repeat this performance test.
3. Suspect the A10 digital IF board assembly if the analyzer still fails the test.

11. Test Port Receiver Magnitude Dynamic Accuracy

Required Equipment

| Description | Model Number or Part Number |
|---|------------------------------------|
| Power Meter | 436A/437B/438A or E4418B/E4419B |
| Power Sensor | 8482A |
| Step Attenuator, 110 dB See notes on the following page. | 8496A Option 003, H18 |
| Adapter (2), APC-7 to Type-N (f) | 11525A |
| Cable, GPIB | 10833A |
| Calibration Kit, 7-mm, 50Ω | 85031B |
| Attenuator, 20 dB | 8492A Option 020 |
| Cable, APC-7, 50Ω | part number 8120-4779 |

Analyzer warmup time: 30 minutes

NOTE

The 8496A step attenuator (Option 003, H18) comes with a special calibration that supports the measurement uncertainties expressed in the test record for this performance test.

The special calibration consists of two measurements. The first is a measurement of the attenuation at each step. The data reported for this measurement have the following uncertainties:

- ± 0.006 dB from 0 to 40 dB
- ± 0.015 dB from >40 to 80 dB
- ± 0.025 dB from >80 to 90 dB
- ± 0.05 dB >90 dB

The second calibration measurement characterizes match stability between attenuator settings for each attenuator port. The vector difference of S11 or S22 between the reference attenuation step and all the other steps is measured. The magnitude of this difference is certified to be < 0.0316 (>30 dB).

NOTE

The 8496A used for this test will have known attenuator errors for attenuations up to 100 dB using a test frequency of 30 MHz. The attenuation used as a reference is 0 dB. If the available calibration data is not expressed as attenuation errors, it can be converted to such a form by the following equation:

$$(\text{actual attenuation}) - (\text{expected attenuation}) = \text{attenuator error}$$

Actual attenuation values that are greater than the expected attenuation values will result in positive errors. Actual attenuation values that are less than the expected attenuation values will result in negative errors.

Initial Calculations

1. Fill in the attenuator error values (refer to 0 dB attenuation) by referring to the calibration data for the 8496A step attenuator. Refer to the note on the previous page.
 - a. Find the column in the 8496A attenuation error table pertaining to the attenuation errors for 30 MHz.
 - b. Starting with the 10 dB step in this column, write down the value in the corresponding space in [Table 1-3](#) for column B. This value should be placed in the row for the 10 dB 8496A setting.
2. Continue transferring the remaining values of the 8496A attenuation errors to column B in [Table 1-3 on page 1-112](#).

System Verification and Performance Tests
Performance Tests

- In [Table 1-3](#), transfer the 10 dB error value located within the parenthesis in column B to each space in column C.

Table 1-3 Magnitude Dynamic Accuracy Calculations

| A | B | C | D: (B-C) | E | F: (E-D) |
|------------------|------------------------|-------------------|-------------------------|---------------------------|---------------------------------------|
| 8496A Attn. (dB) | Attn. Error (ref 0 dB) | 10 dB Error Value | Attn. Error (ref 10 dB) | Expected Measurement (dB) | Expected Measurement (corrected) (dB) |
| 0 | 0 dB | | | 10 | |
| 10 | (.....) | | 0 dB | 0 | |
| 20 | | | | -10 | |
| 30 | | | | -20 | |
| 40 | | | | -30 | |
| 50 | | | | -40 | |
| 60 | | | | -50 | |
| 70 | | | | -60 | |
| 80 | | | | -70 | |
| 90 | | | | -80 | |
| | | | | | |

- The values in column D result from changing the reference attenuation of the calibration data of the 8496A to 10 dB.
 Calculate the attenuation error values for this column by subtracting the values in column C from the values in column B ($B - C = D$).
- The values in column F result from correcting the expected measurement value by the amount of attenuator error.
 Calculate the attenuation error values for this column by subtracting the values in column D from the values in column E ($E - D = F$).
- Transfer the values from column F in [Table 1-3](#) to column F in the performance test record for both ports.

Power Meter Calibration

1. Zero and calibrate the power meter. (Refer to the power meter manual for details on this procedure.)
2. Connect the equipment as shown in [Figure 1-51](#).

Figure 1-51 Power Meter Calibration for Magnitude Dynamic Accuracy
NETWORK ANALYZER

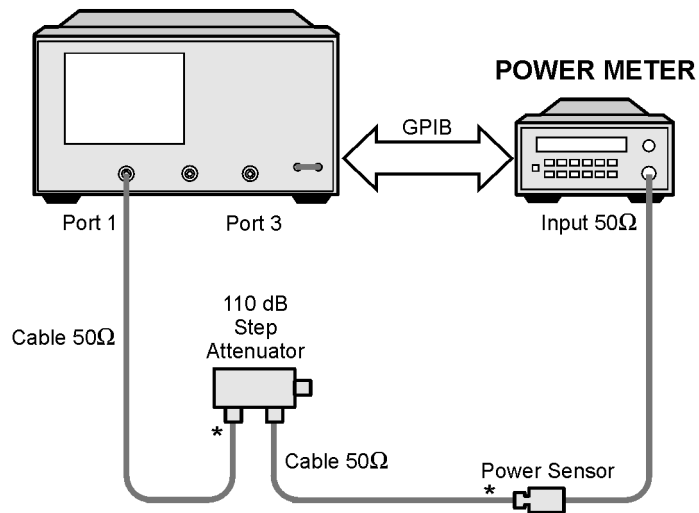

* Direct Connection

ue532o

3. Set the 8496A to 10 dB.
 - Set the following analyzer parameters by pressing:
 - **Preset, Sweep Setup, CW FREQ, 30, M/μ**
 - **NUMBER of POINTS, 51, x1**
 - **Power, -10, x1**
 - **Avg, IF BW, 10, x1**

System Verification and Performance Tests

Performance Tests

4. Set up the analyzer for power meter calibration:
 - a. Select the analyzer as the system controller:
 - **Local**
 - **SYSTEM CONTROLLER**
 - b. Set the power meter's address:
 - **SET ADDRESSES**
 - **ADDRESS:P MTR/GPIB, 13, x1**
 - c. Select the appropriate power meter by pressing **POWER MTR** until the correct model number is displayed (436A, 437B, 438A).
 - d. Select the power meter cal and enter the power sensor calibration data by pressing:
 - **Cal, CAL KIT, SELECT CAL KIT, 7mm 85031**
 - **Cal, PWRMTR CAL, LOSS/SENSOR LISTS, CAL FACTOR SENSOR A** (enter the power sensor calibration data for 30 MHz), **DONE**
5. Take a power meter calibration sweep.
 - **Cal, PWRMTR CAL, -20, x1**
 - **ONE SWEEP, TAKE CAL SWEEP**
6. Verify that the power meter reads approximately -20 dBm.

Full 2-Port Calibration

1. Connect the equipment as shown in [Figure 1-52](#).

Figure 1-52 Full 2-Port Calibration

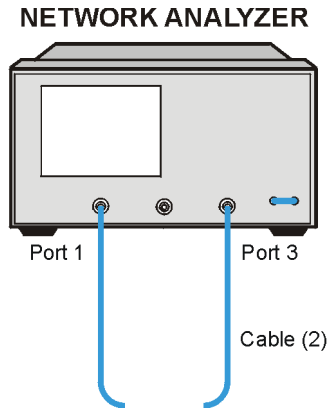

2. Perform a full 2-port error correction with isolation using the 85031B calibration kit.

NOTE

When you are performing error-correction for a system that has type-N port connectors, the softkey menus label the sex of the port connector—not the calibration standard connector. For example, the label **SHORT (F)** refers to the short connected to the female port.

Measure Port 2 Magnitude Dynamic Accuracy

1. Connect the equipment as shown in [Figure 1-53](#). Confirm that the step attenuator is set to 110 dB.

Figure 1-53 Magnitude Dynamic Accuracy Measurement

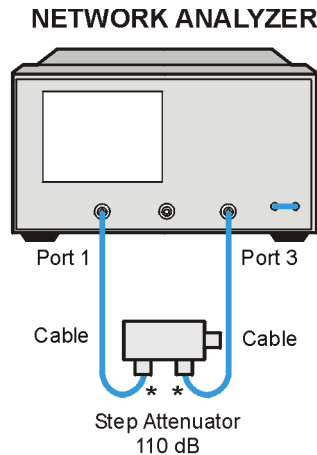

* Direct Connection

ue534c

2. To set up the dynamic accuracy measurement, press the following:
 - Meas, Trans: FWD S31 (B/R)
 - Marker Fctn, MARKER MODE MENU, MKR STATS ON
 - Sweep Setup, TRIGGER MENU, SINGLE
3. Wait for the sweep to finish, then press **Display, DATA → MEM, DATA/MEM.**
4. Set the step attenuator to 0 dB.
5. Press **Sweep Setup, TRIGGER MENU, SINGLE.**
6. Press **Scale Ref, REFERENCE POSITION, 8, x1.**
7. Write the mean value (that appears on the analyzer's display) in the "Test Port Measurement" column of the performance test record. This column is also labeled G.

8. Repeat steps 3 through 7 for each setting of the step attenuator as written in the performance test record.
9. Calculate dynamic accuracy for each step by using the formula $|G-F|$. Place these values in the appropriate column of the performance test record.

Measure Port 1 Magnitude Dynamic Accuracy

1. Set the step attenuator to 10 dB.
2. To set up the dynamic accuracy measurement, press the following:
 - **Meas, Trans:REV S13 (A/R)**
 - **Display, DATA**
 - **Sweep Setup, TRIGGER MENU, SINGLE**
3. Wait for the sweep to finish, then press **Display, DATA → MEM, DATA/MEM**.
4. Set the step attenuator to 0 dB.
5. Press **Sweep Setup, TRIGGER MENU, SINGLE**.
6. Press **Scale Ref, REFERENCE POSITION, 8, x1**.
7. Write the mean value (that appears on the analyzer's display) in the "Port Measurement" column of the performance test record. This column is also labeled G.
8. Repeat steps 3 through 7 for each setting of the step attenuator as written in the performance test record.
9. Calculate dynamic accuracy for each step by using the formula $|G-F|$ (as absolute value). Place these values in the appropriate column of the performance test record.

R-Channel Magnitude Dynamic Accuracy

1. Press **Preset**.
2. Connect the equipment as shown in [Figure 1-54](#).

Figure 1-54 R-Channel Magnitude Dynamic Accuracy Test Setup

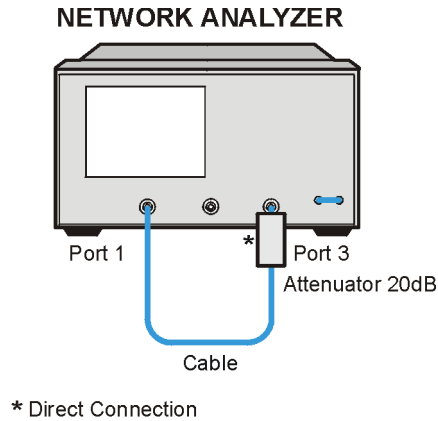

ue535o

3. Press **Avg, IF BW, 10, x1**.
4. Press **Sweep Setup, NUMBER of POINTS, 51, x1, CW FREQ, 30, M/μ, SWEEP TYPE MENU, POWER SWEEP**.
5. Press **Meas, INPUT PORTS, B**.
6. Press **Marker, -15, x1**.
7. Press **Marker, MARKER 2, -10, x1**.
8. Press **MARKER 3, -5, x1**.
9. Press **MARKER 4, 0, x1**.
10. Press **MARKER 5, 5, x1**.
11. Press **Δ MODE MENU, Δ REF = 2**.
12. Press **Chan 2, Meas, INPUT PORTS, R**.
13. Press **Display, DUAL | QUAD SETUP, DUAL CHAN ON**.
14. Press **Sweep Setup, TRIGGER MENU, SINGLE**.
15. Press **Display, MORE, D2/D1 TO D2 ON**.

16. For each marker up to marker 5, read the values of D2 and D1 from the channel 2 display and record onto the performance test record in the “R-Channel” section.

To obtain values for marker 5, press **Marker, MARKER 5, 20, x1, Sweep Setup, TRIGGER MENU, SINGLE**.

17. Repeat step 15 and record the value on the performance test record for marker 5.

In Case of Difficulty

1. If the analyzer fails the test at *all* power levels, be sure you followed the recommended attenuator settings as listed in the performance test record. Repeat this performance test.
2. If both port measured values are out of specification:
 - a. Recalibrate the power meter.
 - b. Repeat this performance test.
3. If the analyzer fails either Port 3 or Port 1 dynamic accuracy at lower power levels:
 - a. Perform the IF amplifier correction constants and ADC offset correction constants procedures in the standard documentation.
 - b. Repeat this performance test.
 - c. If it still fails, replace the A10 digital IF assembly.
 - d. Repeat the two adjustment procedures mentioned in the previous step, then repeat this performance test.

12. Test Port Receiver Magnitude Compression

Perform this test to verify the magnitude compression/expansion of the analyzer's test port receivers.

Specifications

| Frequency Range | Magnitude ^a |
|-----------------------------|------------------------|
| 300 kHz to 3 GHz | ≤0.45 dB |
| 3 GHz to 6 GHz ^b | ≤0.80 dB |

- a. With a 10 Hz IF bandwidth
- b. Option 006 only

Required Equipment

| Description | Model Number or Part Number |
|-----------------------|------------------------------|
| Cable (2), 50Ω, APC-7 | part number 8120-4779 |
| Step Attenuator | 8496A Option 003, Option H18 |

Analyzer warmup time: 30 minutes

Procedure

1. Connect the equipment as shown in [Figure 1-55](#).

Figure 1-55 Port Receiver Magnitude Compression Test Setup

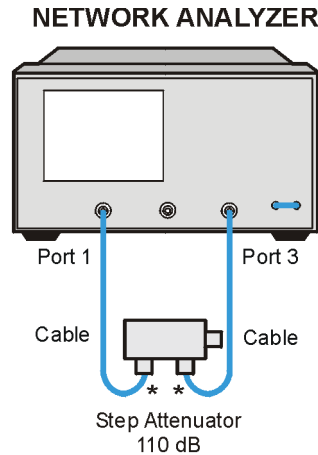

ue534c

2. On the analyzer, press **Preset, Avg, IF BW, 10, x1**.
3. Press **Meas, INPUT PORTS, B**.
4. Press **Sweep Setup, SWEEP TYPE MENU, POWER SWEEP, Start, -10, x1**.
5. Press **Sweep Setup, CW FREQ, 50, M/μ**.
6. Set the step attenuator to 20 dB attenuation.
7. Press **TRIGGER MENU, SINGLE**.
8. Wait for the sweep to finish, then press **Display, DATA → MEM, DATA/MEM**.
9. Set the step attenuator to 0 dB.
10. Press **Sweep Setup, TRIGGER MENU, SINGLE**.
11. Press **Scale Ref, AUTO SCALE**.

Performance Tests

12. Press **Marker**, **ΔMODE MENU**, **FIXED MKR POSITION**, **FIXED MKR STIMULUS**, **RETURN**, **ΔREF = ΔFIXED MKR**.
13. Press **Marker**, **MARKER 1**, **Marker Search**, **SEARCH: MAX**.
14. Press **Marker**, **MARKER 2**, **Marker Search**, **SEARCH: MIN**.
15. (Perform this step only for the first CW frequency.) Press **Marker**, **ΔMODE MENU**, **ΔREF = 1**.
16. Read the value of both markers and enter the largest absolute value in the performance test record under “Measured Value Test Port 3.”
17. Repeat steps 5 through 14 for each CW frequency listed in the performance test record.
18. Press **Meas**, **INPUT PORTS**, **A**, **TESTPORT 2**.
19. Repeat steps 5 through 14 for each CW frequency listed in the performance test record. For step 15, record the values in the performance test record under “Measured Value Test Port 1.”

In Case of Difficulty

1. If the analyzer fails Port 3 magnitude compression:
 - a. Repeat this test.
 - b. Replace the A6 B sampler assembly if the analyzer still fails the test.
2. If the analyzer fails Port 1 magnitude compression:
 - a. Repeat this test.
 - b. Replace the A5 A sampler assembly if the analyzer still fails the test.

13. Test Port Receiver Phase Compression

Perform this test to verify the phase compression/expansion of the analyzer's test port receivers.

Specifications

| CW Frequency | Port | Phase ^a |
|-----------------------------|--------|--------------------|
| 300 kHz to 3 GHz | Port 1 | ≤6 °C |
| 3 GHz to 6 GHz ^b | Port 1 | ≤7.5 °C |

a. With 10 Hz IF bandwidth

b. Only for analyzers with Option 006

Required Equipment

| Description | Model Number or Part Number |
|-----------------------|------------------------------|
| Cable, (2), 50Ω APC-7 | part number 8120-4779 |
| Step Attenuator | 8496A Option 003, Option H18 |

Analyzer warmup time: 30 minutes

Procedure

1. Connect the equipment as shown in [Figure 1-56](#).

Figure 1-56 Port Phase Compression Test Setup

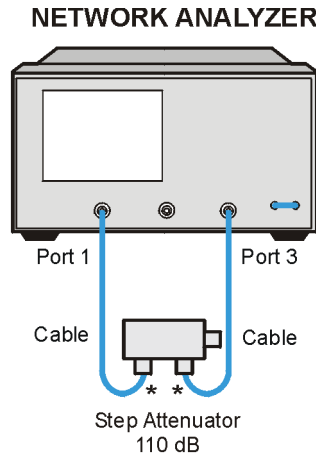

* Direct Connection

ue534c

2. Press **Preset**, **IF BW**, **10**, **x1**.
3. Press **Meas**, **INPUT PORTS**, **B**, **Format**, **PHASE**.
4. Press **Sweep Setup**, **SWEEP TYPE MENU**, **POWER SWEEP**, **Start**, **-10**, **x1**.
5. Press **Sweep Setup**, **CW FREQ**, **50**, **M/μ**.
6. Set the step attenuator to 20 dB attenuation.
7. Press **TRIGGER MENU**, **SINGLE**.
8. Press **Display**, **DATA** → **MEM**, **DATA/MEM**.
9. Set the step attenuator to 0 dB attenuation.
10. Press **Sweep Setup**, **TRIGGER MENU**, **SINGLE**.
11. Press **Scale Ref**, **AUTO SCALE**.

12. Press **Marker**, **ΔMODE MENU**, **FIXED MKR POSITION**, **FIXED MKR STIMULUS**, **RETURN**, **ΔREF = ΔFIXED MKR**.
13. Press **Marker**, **MARKER 1**, **Marker Search**, **SEARCH: MAX**.
14. Press **Marker**, **MARKER 2**, **Marker Search**, **SEARCH: MIN**.
15. (Perform this step only for the first CW frequency listed in the performance test record.) Press **Marker**, **ΔMODE MENU**, **ΔREF = 1**.
16. Read the value of both markers and enter the largest absolute value in the performance test record under “Measured Value Test Port 3.”
17. Repeat steps 5 through 14 for each CW frequency listed in the performance test record.
18. Press **Meas**, **INPUT PORTS**, **TESTPORT2**.
19. Repeat steps 5 through 14 for each CW frequency listed in the performance test record. Record the entries under “Measured Value Test Port 1.”

In Case of Difficulty

1. If the analyzer fails Port 3 phase compression test:
 - a. Repeat this test.
 - b. Replace the A6 B sampler assembly if the analyzer still fails the test.
2. If the analyzer fails Port 1 phase compression test:
 - a. Repeat this test.
 - b. Replace the A5 A sampler assembly if the analyzer still fails the test.

14. Test Port Output/Input Harmonics

(Option 002 Analyzers)

Perform this test to determine the spectral purity of the input and output test ports.

Specifications

| Port | Harmonic | Limit |
|--------------|----------|---------------------------------------|
| Output | 2nd | $\leq 25\text{dBc @ } +10\text{ dBm}$ |
| Output | 3rd | $\leq 25\text{dBc @ } +10\text{ dBm}$ |
| Input Port 1 | 2nd | $< -15\text{dBc @ } +10\text{ dBm}$ |
| Input Port 1 | 3rd | $< -30\text{dBc @ } +10\text{ dBm}$ |
| Input Port 3 | 2nd | $< -15\text{dBc @ } +10\text{ dBm}$ |
| Input Port 3 | 3rd | $< -30\text{dBc @ } +10\text{ dBm}$ |

Required Equipment

| Description | Model Number or Part Number |
|------------------------------------|-----------------------------|
| Cable, 50 Ω Type-N, 24-inch | part number 8120-4781 |
| Attenuation (2), 20 dB, Type-N | 8491A Option 020 |

Analyzer warmup time: 30 minutes

Port Output Worst-Case 2nd Harmonic

1. Press **Preset, Power, 10, x1**.
2. Press **Start, 16, M/ μ , Stop, 1.5, G/n** to set the frequency range.
3. Press **Avg, IF BW, 10, x1** to set the IF bandwidth to 10 Hz.
4. Connect the equipment as shown in [Figure 1-57](#).

Figure 1-57 Port Output Harmonics Test Setup

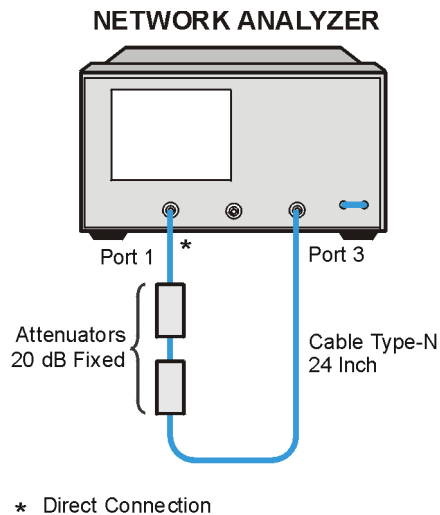

ue536o

5. Press **Meas, Trans: REV S13 (A/R), INPUT PORTS, A**.
6. After one sweep, press **Display, DATA → MEMORY, DATA/MEM** to normalize the trace.
7. Press **System, HARMONIC MEAS, HARMONIC SECOND**.
8. After one sweep, press **Scale Ref, AUTO SCALE** to get a better view of the trace.
9. Press **Marker Search, SEARCH MAX**.
10. Write the marker 1 value that appears on the analyzer display on the performance test record. This is the worst-case test port output 2nd harmonic.

Port Output Worst-Case 3rd Harmonic

1. *For analyzers without Option 006:* Press **Stop, 1, G/n** to change the stop frequency to 1 GHz.
2. *For analyzers with Option 006:* Press **Stop, 2, G/n** to change the stop frequency to 1 GHz.
3. Press **System, HARMONIC MEAS, HARMONIC OFF.**
4. After one sweep, press **Display, DATA → MEMORY, DATA/MEM** to normalize the trace.
5. Press **Scale Ref, AUTO SCALE, SCALE/DIV, 1, x1** to get a better view of the trace.
6. Press **System, HARMONIC MEAS, HARMONIC THIRD.**
7. After one sweep, press **Scale Ref, AUTO SCALE.**
8. Press **Marker Search, SEARCH: MAX.**
9. Write the marker 1 value on the performance test record.

Port 1 Input Worst-Case 2nd Harmonic

1. Connect the equipment as shown in [Figure 1-58](#).

Figure 1-58 Receiver Harmonics Test Setup

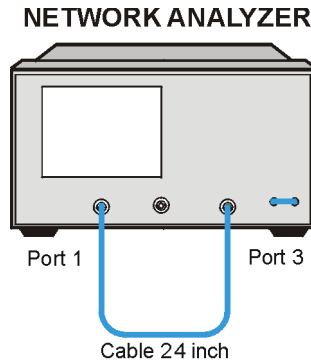

ue515c

2. Press **Preset, Power, 8, x1**.
3. Press **Avg, IF BW, 1, 0, x1**.
4. *For analyzers without Option 006:* Press **Start, 16, M/μ, Stop, 1.5, G/n** to set the frequency range to 1.5 GHz.
5. *For analyzers with Option 006:* Press **Start, 16, M/μ, Stop, 3.0, G/n** to set the frequency range to 3.0 GHz.
6. Press **Meas, Trans: REV S12 (A/R), INPUT PORTS, A**.
7. After one sweep, press **Display, DATA → MEMORY, DATA/MEM** to normalize the trace.
8. Press **System, HARMONIC MEAS, HARMONIC SECOND**.
9. After one sweep, press **Scale Ref, AUTO SCALE** to get a better view of the trace.
10. Write the marker 1 value that appears on the analyzer display on the performance test record. This is the worst-case Port 1 input (receiver channel A) 2nd harmonic.

Port 1 Input Worst-Case 3rd Harmonic

1. *For analyzers without Option 006:* Press **Stop, 1, G/n** to change the stop frequency to 1 GHz.
2. *For analyzers with Option 006:* Press **Stop, 2, G/n** to change the stop frequency to 1 GHz.
3. Press **System, HARMONIC MEAS, HARMONIC OFF.**
4. After one sweep, press **Display, DATA → MEMORY, DATA/MEM** to normalize the trace.
5. Press **Scale Ref, AUTO SCALE, SCALE/DIV, 1, x1** to get a better view of the trace.
6. Press **System, HARMONIC MEAS, HARMONIC THIRD.**
7. After one sweep, press **Scale Ref, AUTO SCALE.**
8. Press **Marker Search, SEARCH: MAX.**
9. Write the marker 1 value on the performance test record.
10. Press **System, HARMONIC MEAS, HARMONIC OFF.**

Port 3 Input Worst-Case 2nd Harmonic

1. *For analyzers without Option 006:* Press **Start, 16, M/μ, Stop, 1.5, G/n** to set the stop frequency for measuring the 2nd harmonic.
2. *For analyzers with Option 006:* Press **Start, 16, M/μ, Stop, 3.0, G/n** to set the stop frequency for measuring the 2nd harmonic.
3. Press **Meas, Trans: REV S31 (B/R), INPUT PORTS, B.**
4. After one sweep, press **Display, DATA → MEMORY, DATA/MEM** to normalize the trace.
5. Press **System, HARMONIC MEAS, HARMONIC SECOND.**
6. After one sweep, press **Scale Ref, AUTO SCALE** to get a better view of the trace.
7. Write the marker 1 value that appears on the analyzer display on the performance test record. This is the worst-case Port 3 input (receiver channel B) 2nd harmonic.

Port 3 Input Worst-Case 3rd Harmonic

1. *For analyzers without Option 006:* Press **Stop, 1.5, G/n** to set the stop frequency for measuring the receiver's 3rd harmonic.
2. *For analyzers with Option 006:* Press **Stop, 3.0, G/n** to set the stop frequency for measuring the receiver's 3rd harmonic.
3. Press **System, HARMONIC MEAS, HARMONIC OFF.**
4. After one sweep, press **Display, DATA → MEMORY, DATA/MEM** to normalize the trace.
5. Press **Scale Ref, AUTO SCALE, SCALE/DIV, 1, x1** to get a better view of the trace.
6. Press **System, HARMONIC MEAS, HARMONIC THIRD.**
7. After one sweep, press **Scale Ref, AUTO SCALE.**
8. Press **Marker Search, SEARCH: MAX.**
9. Write the marker 1 value on the performance test record.

15. Harmonic Measurement Accuracy

Perform this test to verify the analyzer's accuracy when operating in the harmonic measurement mode (Option 002). The analyzer's reading is compared to that of a power meter. The allowable difference (accuracy) is shown in the "Specifications" table.

Specifications

| Frequency Range | Accuracy |
|-----------------------------|----------|
| 16 MHz to 3 GHz | 1.5 dB |
| 3 GHz to 6 GHz ^a | 3.0 dB |

a. Only for analyzers with Option 006

Required Equipment

| Description | Model Number or Part Number |
|---|----------------------------------|
| External Source | 83712B |
| Power Meter | 436A/437B/438A or 4418B/4419B |
| Power Splitter | 11667A Option 001 |
| Power Sensor | 8482A |
| Adapter, Type-N (f) to Type-N (f) | part number 1250-0777 |
| Cable (2) 50Ω, Type-N, 24-inch | part number 8120-4781 |
| Cable, BNC, 24-inch | part number 8120-1840 |
| Additional equipment needed for analyzers with Option 006: | |
| Power Sensor | 8481A |

Analyzer warmup time: 30 minutes

Determine the Cable Loss at Specified Frequencies

1. Connect the equipment as shown in [Figure 1-59](#).

Figure 1-59 Harmonic Measurement Accuracy, Cable Loss Setup 1

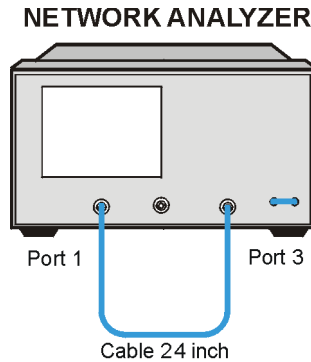

ue515c

2. Press **Preset, Start, 40, M/μ.**
3. Press **Meas, Trans: S31 (B/R), Cal, CALIBRATE MENU, RESPONSE, THRU.**

System Verification and Performance Tests
Performance Tests

4. Disconnect the cable from Port 3. Connect the type-N (f) to type-N (f) adapters to the end of the cable and attach the second type-N cable as shown in [Figure 1-60](#).

Figure 1-60 Harmonic Measurement Accuracy, Cable Loss Setup 2

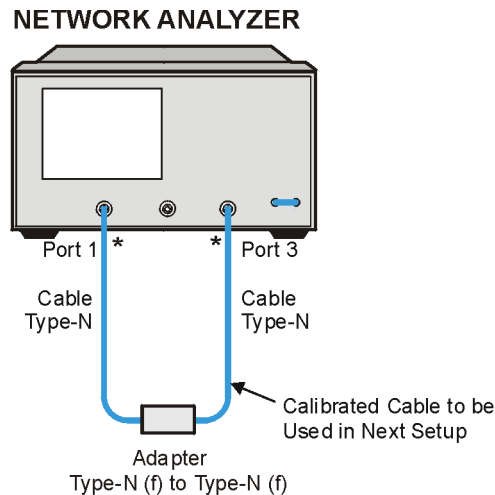

* Direct Connection

ue537o

5. Press **Scale Ref, SCALE/DIV, 1, x1**.
6. Press **Sweep Setup, TRIGGER MENU, SINGLE**.
7. Press **Marker**. Enter the first external source frequency (40 MHz) by pressing **40, M/μ**. Read the value of the marker shown in dB in the upper right of the display. Enter this value in the performance test record under "Cable Loss." Repeat this step for all external source frequencies listed in the performance test record.

Instrument Setup

1. Zero and calibrate the power meter.
2. Set up the equipment as shown in [Figure 1-61](#). For the type-N cable, use the one added in step 4 on the previous page.
3. On the analyzer:
Press **Preset**, **Avg**, **IF BW**, **1**, **k/m**, **Meas**, **INPUT PORTS**, **B**.
Press **Scale Ref**, **SCALE/DIV**, **1**, **x1**.
Press **Marker Fctn**, **MARKER MODE MENU**, **STATS ON**.
4. On the external source, set the power level for 6 dBm.

Figure 1-61 Harmonic Measurement Accuracy Test Setup

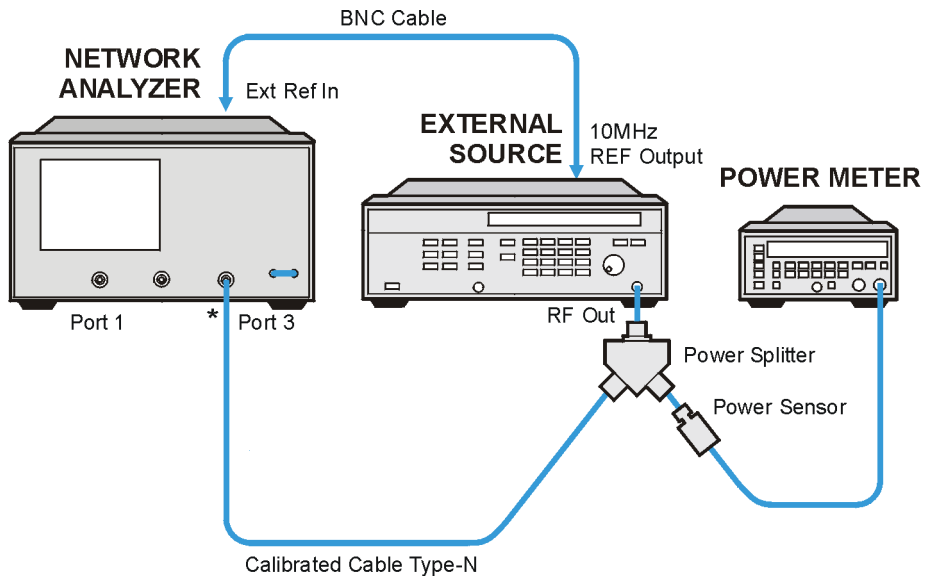

* Direct Connection

ue538o

Harmonic Measurement Accuracy

1. On the analyzer, press **System, HARMONIC MEAS, SECOND**, then press **Sweep Setup, CW FREQ, 20, M/μ**.
2. Set the external source for CW operation at 40 MHz (the second harmonic).
3. On the analyzer, press **TRIGGER MENU, SINGLE**. Record the “mean” reading of the marker in the performance test record under “Network Analyzer Reading” for the second harmonic (40 MHz).
4. On the power meter, set the cal factor appropriate for the frequency of the external source. Record the power meter reading in the performance test record under “Power Meter Meas” for the second harmonic (40 MHz).
5. Set the external source for CW operation at 60 MHz (third harmonic).
6. On the analyzer, press **System, HARMONIC MEAS, THIRD**, then press **Sweep Setup, TRIGGER MENU, SINGLE**. Record the “mean” reading of the marker in the performance test record under “Network Analyzer Reading” for the third harmonic (60 MHz).
7. On the power meter, set the cal factor appropriate for the frequency of the external source. Record the power meter reading on the performance test record under “Power Meter Meas” for the third harmonic (60 MHz).
8. Repeat steps 4 through 7 for the second and third harmonics of the other analyzer frequencies.

In Case of Difficulty

1. Check all connections.
2. Ensure that correct power meter cal factors were used.
3. Refer to [Chapter 3, “Theory of Operation and Troubleshooting.”](#)

Performance Test Records

The performance test records in this chapter include entries up to 6 GHz for analyzers with Option 006 (6 GHz operation). If your analyzer does not have Option 006, write "N/A" for entries above 3 GHz.

Option H39 Performance Test Record

| | | | |
|---------------------------------|---------------------|-----------------------|---------------------|
| Calibration Lab Address: | | Report Number | |
| | | Date | |
| | | Last Calibration Date | |
| | | Customer's Name | |
| | | Performed by | |
| Model 8753ES | | | |
| Option H39 | | | |
| Serial No. | | Option | |
| Firmware Revision | | | |
| Ambient Temperature | °C | Relative Humidity | % |
| Test Equipment Used | | | |
| Description | Model Number | Trace Number | Cal Due Date |
| Frequency Counter | | | |
| Power Meter | | | |
| Power Sensor | | | |
| Calibration Kit | | | |
| Verification Kit | | | |
| Step Attenuator | | | |
| Notes/Comments | | | |
| | | | |
| | | | |

Performance Test Records
Option H39 Performance Test Record

| Model 8753ES Option H39 | | Report Number | | |
|--|-------------|------------------------|-------------|---------------------|
| Serial Number | | | | |
| Option(s) | | Date | | |
| 1. Test Port Output Frequency Range and Accuracy | | | | |
| Note: If your analyzer does not have Option 006, write "N/A" in all entries above 3 GHz. | | | | |
| CW Frequency (MHz) | Min. (MHz) | Results Measured (MHz) | Max. (MHz) | Meas. Uncert. (MHz) |
| 0.03 | 0.029 999 7 | | 0.030 000 3 | ±0.000 000 050 |
| 0.3 | 0.299 997 | | 0.300 003 | ±0.000 000 520 |
| 5.0 | 4.999 950 | | 5.000 050 | ±0.000 008 610 |
| 16.0 | 15.999 840 | | 16.000 160 | ±0.000 028 220 |
| 31.0 | 30.999 690 | | 31.000 310 | ±0.000 0530 730 |
| 60.999 999 | 60.999 390 | | 61.000 610 | ±0.000 104 800 |
| 121.0 | 120.998 790 | | 121.001 210 | ±0.000 206 800 |
| 180.0 | 179.998 200 | | 180.001 800 | ±0.000 307 200 |
| 310.0 | 309.995 900 | | 310.003 100 | 0.000 528 300 |
| 700.0 | 699.930 000 | | 700.007 000 | ±0.001 191 700 |
| 1 300.0 | 1 299.987 | | 1 300.013 | ±0.002 212 300 |
| 2 000.0 | 1 999.980 | | 2 000.020 | ±0.003 403 000 |
| 3 000.0 | 2 999.970 | | 3 000.030 | ±0.005 104 000 |
| 4 000.0 | 3 999.960 | | 4 000.040 | ±0.006 805 000 |
| 5 000.0 | 4 999.950 | | 5 000.050 | ±0.008 506 000 |
| 6 000.0 | 5 999.940 | | 6 000.060 | ±0.010 207 000 |

| | |
|--|----------------------|
| Model 8753ES Option H39 | Report Number |
| Serial Number | |
| Option(s) | Date |
| 2. External Source Mode Frequency Range | |
| Note: If your analyzer does not have Option 006, write "N/A" in all entries above 3 GHz. | |
| Test Frequencies (GHz) | Results |
| 0.010 | |
| 0.020 | |
| 0.100 | |
| 1.000 | |
| 2.000 | |
| 3.000 | |
| 4.000 | |
| 5.000 | |
| 6.000 | |

Performance Test Records
Option H39 Performance Test Record

| Model 8753ES Option H39 | | | Report Number | |
|--|------------------------------|--------------------|----------------------|------------------------------|
| Serial Number | | | | |
| Option(s) | | | Date | |
| 3. Test Port Output Power Level Accuracy | | | | |
| Note: If your analyzer does not have Option 006, write "N/A" in all entries above 3 GHz. | | | | |
| Test Frequency | Test Port Output Power (dBm) | Specification (dB) | Measured Value (dBm) | Measurement Uncertainty (dB) |
| 300 kHz | 0 | ±1 | | ±0.47 |
| 20 MHz | 0 | ±1 | | ±0.14 |
| 50 MHz | 0 | ±1 | | ±0.14 |
| 100 MHz | 0 | ±1 | | ±0.14 |
| 200 MHz | 0 | ±1 | | ±0.14 |
| 500 MHz | 0 | ±1 | | ±0.14 |
| 1 GHz | 0 | ±1 | | ±0.13 |
| 2 GHz | 0 | ±1 | | ±0.13 |
| 3 GHz | 0 | ±1 | | ±0.27 |
| 4 GHz | 0 | ±1 | | ±0.17 |
| 5 GHz | 0 | ±1 | | ±0.17 |
| 6 GHz | 0 | ±1 | | ±0.17 |

| Model 8753ES Option H39 | | | Report Number | |
|--|-----------------------------|--------------------------|-----------------------|--------------------------|
| Serial Number | | | | |
| Option(s) | | | Date | |
| 4. Test Port Output Power Linearity | | | | |
| Frequency Range: 300 kHz to 3 GHz | | | | |
| Note: If your analyzer does not have Option 006, write "N/A" in all entries above 3 GHz. | | | | |
| Power Setting dBm | Marker 1 Maximum (dB) | Marker 2 Minimum (dB) | Specification (dB) | Meas. Uncert. (dB) |
| -15 | | | ± 0.2 | ± 0.04 |
| -13 | | | ± 0.2 | ± 0.03 |
| -11 | | | ± 0.2 | ± 0.03 |
| -9 | | | ± 0.2 | ± 0.03 |
| -7 | | | ± 0.2 | ± 0.03 |
| -5 | | | ± 0.2 | ± 0.03 |
| -3 | | | ± 0.2 | ± 0.02 |
| -1 | | | ± 0.2 | ± 0.02 |
| +1 | | | ± 0.2 | ± 0.02 |
| +3 | | | ± 0.2 | ± 0.02 |
| +5 | | | ± 0.2 | ± 0.03 |
| +7 | | | ± 0.5 | ± 0.03 |
| +8 | | | ± 0.5 | ± 0.03 |
| +9 | | | ± 0.5 | ± 0.03 |
| +10 | | | ± 0.5 | ± 0.03 |

Performance Test Records
Option H39 Performance Test Record

| Model 8753ES Option H39 | | | Report Number | |
|--|--------------------------------------|----------------------------------|-------------------------------|-----------------------------------|
| Serial Number | | | | |
| Option(s) | | | Date | |
| 4. Test Port Output Power Linearity (continued) | | | | |
| Frequency Range: 3 GHz to 6 GHz | | | | |
| Note: If your analyzer does not have Option 006, write "N/A" in all entries above 3 GHz. | | | | |
| Power Setting dBm | Marker 1 Maximum (dB) | Marker 2 Minimum (dB) | Specification (dB) | Meas. Uncert. (dB) |
| -15 | | | ±0.2 | ±0.04 |
| -13 | | | ±0.2 | ±0.03 |
| -11 | | | ±0.2 | ±0.03 |
| -9 | | | ±0.2 | ±0.03 |
| -7 | | | ±0.2 | ±0.03 |
| -5 | | | ±0.2 | ±0.03 |
| -3 | | | ±0.2 | ±0.02 |
| -1 | | | ±0.2 | ±0.02 |
| +1 | | | ±0.2 | ±0.02 |
| +3 | | | ±0.2 | ±0.02 |
| +5 | | | ±0.2 | ±0.03 |
| +7 | | | ±0.5 | ±0.03 |
| +8 | | | ±0.5 | ±0.03 |
| +9 | | | ±0.5 | ±0.03 |
| +10 | | | ±0.5 | ±0.03 |

| Model 8753ES Option H39 | | Report Number | |
|--|---------------------|----------------------|-------------------------|
| Serial Number | | | |
| Option(s) | | Date | |
| 5. Minimum R Channel Level | | | |
| Note: If your analyzer does not have Option 006, write "N/A" in all entries above 3 GHz. | | | |
| CW Frequency | Specification (dBm) | Test Port Power | Measurement Uncertainty |
| 300 kHz | ≤35 | | ±1.0 |
| 3.29 MHz | ≤35 | | ±1.0 |
| 3.31 MHz | ≤35 | | ±1.0 |
| 15.90 MHz | ≤35 | | ±1.0 |
| 16.10 MHz | ≤35 | | ±1.0 |
| 30.90 MHz | ≤35 | | ±1.0 |
| 31.10 MHz | ≤35 | | ±1.0 |
| 1.6069 GHz | ≤35 | | ±1.0 |
| 1.6071 GHz | ≤35 | | ±1.0 |
| 3.000 GHz | ≤35 | | ±2.0 |
| 4.000 GHz | ≤30 | | ±2.0 |
| 5.000 GHz | ≤30 | | ±2.0 |
| 6.000 GHz | ≤30 | | |

Performance Test Records
Option H39 Performance Test Record

| Model 8753ES Option H39 | | | Report Number | | |
|--|-----------|--------------|----------------------|------------------|--------------------|
| Serial Number | | | | | |
| Option(s) | | | Date | | |
| 6. Test Port Input Noise Floor Level | | | | | |
| Note: If your analyzer does not have Option 006, write “N/A” in all entries above 3 GHz. | | | | | |
| Frequency Range | Test Port | IF Bandwidth | Specification (dBm) | Calculated Value | Meas. Uncert. (dB) |
| 300 kHz – 3 GHz | Port 1 | 3 kHz | ≤ -81 | | ± 2.0 |
| | Port 1 | 10 Hz | ≤ -102 | | ± 2.0 |
| | Port 2B | 10 Hz | ≤ -102 | | ± 2.0 |
| | Port 2B | 3 kHz | ≤ -81 | | ± 2.0 |
| 3 GHz – 6 GHz | Port 2B | 3 kHz | ≤ -76 | | ± 2.0 |
| | Port 2B | 10 Hz | ≤ -97 | | ± 2.0 |
| | Port 1 | 10 Hz | ≤ -97 | | ± 2.0 |
| | Port 1 | 3 kHz | ≤ -76 | | ± 2.0 |
| 300 kHz – 3 GHz | Port 2A | 3 kHz | ≤ -81 | | ± 2.0 |
| | Port 2A | 10 Hz | ≤ -102 | | ± 2.0 |
| | Port 3 | 10 Hz | ≤ -102 | | ± 2.0 |
| | Port 3 | 3 kHz | ≤ -81 | | ± 2.0 |
| 3 GHz – 6 GHz | Port 3 | 3 kHz | ≤ -76 | | ± 2.0 |
| | Port 3 | 10 Hz | ≤ -97 | | ± 2.0 |
| | Port 2A | 10 Hz | ≤ -97 | | ± 2.0 |
| | Port 2A | 3 kHz | ≤ -76 | | ± 2.0 |

| Model 8753ES Option H39 | | | Report Number | |
|--|-----------|--------------------|----------------------|--------------------|
| Serial Number | | | | |
| Option(s) | | | Date | |
| 7. Test Port Input Frequency Response | | | | |
| Note: If your analyzer does not have Option 006, write “N/A” in all entries above 3 GHz. | | | | |
| Frequency Range | Test Port | Specification (dB) | Measured Value (dB) | Meas. Uncert. (dB) |
| 300 kHz – 3 GHz | Port 3 | ± 1.0 | | 0.47 |
| | Port 2 | 2 dB (p-p) | | N/A |
| | Port 1 | ± 1.0 | | 0.47 |
| | Port 2 | 2 dB (p-p) | | N/A |
| 3 GHz – 6 GHz | Port 1 | ± 2.0 | | 0.17 |
| | Port 2 | 4 dB (p-p) | | N/A |
| | Port 3 | ± 2.0 | | 0.17 |
| | Port 2 | 4 dB (p-p) | | N/A |

Performance Test Records
Option H39 Performance Test Record

| Model 8753ES Option H39 Serial Number | | Report Number | |
|--|-----------------------|------------------------|-----------------------|
| Option(s) | | Date | |
| 8. Test Port Crosstalk | | | |
| Note: If your analyzer does not have Option 006, write "N/A" in all entries above 3 GHz. | | | |
| Test Settings | Specification (dB) | Measured Value (dB) | Meas. Uncert. (dB) |
| Port 1 and Port 3 | | | |
| Crosstalk to Test Port 3 300 kHz – 3 GHz | < -100 | | ±1.0 |
| Crosstalk to Test Port 1 300 kHz – 3 GHz | < -100 | | ±1.0 |
| Crosstalk to Test Port 1 3 GHz – 6 GHz | < -87 | | ±2.0 |
| Crosstalk to Test Port 3 3 GHz – 6 GHz | < -87 | | ±2.0 |
| Port 2 and Port 3 | | | |
| Crosstalk to Test Port 3 300 kHz – 3 GHz | < -100 | | ±1.0 |
| Crosstalk to Test Port 2 300 kHz – 3 GHz | < -100 | | ±1.0 |
| Crosstalk to Test Port 2 3 GHz – 6 GHz | < -87 | | ±2.0 |
| Crosstalk to Test Port 3 3 GHz – 6 GHz | < -87 | | ±2.0 |
| Port 1 and Port 2 | | | |
| Crosstalk to Test Port 2 300 kHz – 3 GHz | < -100 | | ±1.0 |
| Crosstalk to Test Port 1 300 kHz – GHz | < -100 | | ±1.0 |
| Crosstalk to Test Port 1 3 GHz – 6 GHz | < -87 | | ±2.0 |
| Crosstalk to Test Port 2 3 GHz – 6 GHz | < -87 | | ±2.0 |

| Model 8753ES Option H39 Serial Number | | Report Number | | |
|--|-------------------|----------------------|------------------------|-----------------------|
| Option(s) | | Date | | |
| 9. Uncorrected Port Performance, Port 1 and Port 3 | | | | |
| Note: If your analyzer does not have Option 006, write "N/A" in all entries above 3 GHz. | | | | |
| Test Description | Frequency Range | Spec. (dB) | Measured Value (dB) | Meas. Uncert. (dB) |
| Forward Direction Directivity | 300 kHz – 1.3 GHz | ≤35 | | ±0.9 |
| | 1.3 GHz – 3 GHz | ≤30 | | ±0.8 |
| | 3 GHz – 6 GHz | ≤20 | | ±0.8 |
| Forward Direction Source Match | 300 kHz – 1.3 GHz | ≤16 | | ±0.2 |
| | 1.3 GHz – 3 GHz | ≤16 | | ±0.2 |
| | 3 GHz – 6 GHz | ≤12 | | ±0.3 |
| Reverse Direction Trans. Tracking | 300 kHz – 1.3 GHz | ±1.5 | | ±0.006 |
| | 1.3 GHz – 3 GHz | ±1.5 | | ±0.009 |
| | 3 GHz – 6 GHz | ±2.5 | | ±0.021 |
| Forward Direction Refl. Tracking | 300 kHz – 1.3 GHz | ±1.5 | | ±0.001 |
| | 1.3 GHz – 3 GHz | ±1.5 | | ±0.005 |
| | 3 GHz – 6 GHz | ±2.5 | | ±0.020 |
| Reverse Direction Load Match | 300 kHz – 1.3 GHz | ≤18 | | ±0.1 |
| | 1.3 GHz – 3 GHz | ≤16 | | ±0.2 |
| | 3 GHz – 6 GHz | ≤14 | | ±0.2 |

Performance Test Records
Option H39 Performance Test Record

| Model 8753ES Option H39 Serial Number | | Report Number | | |
|--|-------------------|----------------------|---------------------|--------------------|
| Option(s) | | Date | | |
| 9. Uncorrected Port Performance, Port 1 and Port 3 (continued) | | | | |
| Note: If your analyzer does not have Option 006, write "N/A" in all entries above 3 GHz. | | | | |
| Test Description | Frequency Range | Spec. (dB) | Measured Value (dB) | Meas. Uncert. (dB) |
| Forward Direction Load Match | 300 kHz – 1.3 GHz | ≤18 | | ±0.1 |
| | 1.3 GHz – 3 GHz | ≤16 | | ±0.2 |
| | 3 GHz – 6 GHz | ≤14 | | ±0.2 |
| Reverse Direction Directivity | 300 kHz – 1.3 GHz | ≤35 | | ±0.9 |
| | 1.3 GHz – 3 GHz | ≤30 | | ±0.8 |
| | 3 GHz – 6 GHz | ≤20 | | ±0.8 |
| Reverse Direction Source Match | 300 kHz – 1.3 GHz | ≤16 | | ±0.02 |
| | 1.3 GHz – 3 GHz | ≤16 | | ±0.02 |
| | 3 GHz – 6 GHz | ≤12 | | ±0.03 |
| Reverse Direction Refl. Tracking | 300 kHz – 1.3 GHz | ±1.5 | | ±0.001 |
| | 1.3 GHz – 3 GHz | ±1.5 | | ±0.005 |
| | 3 GHz – 6 GHz | ±2.5 | | ±0.020 |
| Forward Direction Trans. Tracking | 300 kHz – 1.3 GHz | ±1.5 | | ±0.006 |
| | 1.3 GHz – 3 GHz | ±1.5 | | ±0.009 |
| | 3 GHz – 6 GHz | ±2.5 | | ±0.021 |

| Model 8753ES Option H39 | | | Report Number | |
|--|-------------------|------------|----------------------|--------------------|
| Serial Number | | | | |
| Option(s) | | | Date | |
| 9. Uncorrected Port Performance, Port 2 and Port 3 | | | | |
| Note: If your analyzer does not have Option 006, write "N/A" in all entries above 3 GHz. | | | | |
| Test Description | Frequency Range | Spec. (dB) | Measured Value (dB) | Meas. Uncert. (dB) |
| Forward Direction Directivity | 300 kHz – 1.3 GHz | ≤35 | | ±0.9 |
| | 1.3 GHz – 3 GHz | ≤30 | | ±0.8 |
| | 3 GHz – 6 GHz | ≤20 | | ±0.8 |
| Forward Direction Source Match | 300 kHz – 1.3 GHz | ≤16 | | ±0.2 |
| | 1.3 GHz – 3 GHz | ≤16 | | ±0.2 |
| | 3 GHz – 6 GHz | ≤12 | | ±0.3 |
| Reverse Direction Trans. Tracking | 300 kHz – 1.3 GHz | ±1.5 | | ±0.006 |
| | 1.3 GHz – 3 GHz | ±1.5 | | ±0.009 |
| | 3 GHz – 6 GHz | ±2.5 | | ±0.021 |
| Forward Direction Refl. Tracking | 300 kHz – 1.3 GHz | ±1.5 | | ±0.001 |
| | 1.3 GHz – 3 GHz | ±1.5 | | ±0.005 |
| | 3 GHz – 6 GHz | ±2.5 | | ±0.020 |
| Reverse Direction Load Match | 300 kHz – 1.3 GHz | ≤18 | | ±0.1 |
| | 1.3 GHz – 3 GHz | ≤16 | | ±0.2 |
| | 3 GHz – 6 GHz | ≤14 | | ±0.2 |

Performance Test Records
Option H39 Performance Test Record

| Model 8753ES Option H39 | | | Report Number | |
|--|-------------------|------------|----------------------|--------------------|
| Serial Number | | | | |
| Option(s) | | | Date | |
| 9. Uncorrected Port Performance, Port 2 and Port 3 (continued) | | | | |
| Note: If your analyzer does not have Option 006, write "N/A" in all entries above 3 GHz. | | | | |
| Test Description | Frequency Range | Spec. (dB) | Measured Value (dB) | Meas. Uncert. (dB) |
| Forward Direction Load Match | 300 kHz – 1.3 GHz | ≤18 | | ±0.1 |
| | 1.3 GHz – 3 GHz | ≤16 | | ±0.2 |
| | 3 GHz – 6 GHz | ≤14 | | ±0.2 |
| Reverse Direction Directivity | 300 kHz – 1.3 GHz | ≤35 | | ±0.9 |
| | 1.3 GHz – 3 GHz | ≤30 | | ±0.8 |
| | 3 GHz – 6 GHz | ≤20 | | ±0.8 |
| Reverse Direction Source Match | 300 kHz – 1.3 GHz | ≤16 | | ±0.02 |
| | 1.3 GHz – 3 GHz | ≤16 | | ±0.02 |
| | 3 GHz – 6 GHz | ≤12 | | ±0.03 |
| Reverse Direction Refl. Tracking | 300 kHz – 1.3 GHz | 1.5 | | ±0.001 |
| | 1.3 GHz – 3 GHz | 1.5 | | ±0.005 |
| | 3 GHz – 6 GHz | 2.5 | | ±0.020 |
| Forward Direction Trans. Tracking | 300 kHz – 1.3 GHz | ±1.5 | | ±0.006 |
| | 1.3 GHz – 3 GHz | ±1.5 | | ±0.009 |
| | 3 GHz – 6 GHz | ±2.5 | | ±0.021 |

| Model 8753ES Option H39 Serial Number | | | Report Number | |
|--|-------------------|---------------|------------------------|-----------------------|
| Option(s) | | | Date | |
| 9. Uncorrected Port Performance, Port 1 and Port 2 | | | | |
| Note: If your analyzer does not have Option 006, write "N/A" in all entries above 3 GHz. | | | | |
| Test Description | Frequency Range | Spec. (dB) | Measured Value (dB) | Meas. Uncert. (dB) |
| Forward Direction Directivity | 300 kHz – 1.3 GHz | ≤35 | | ±0.9 |
| | 1.3 GHz – 3 GHz | ≤30 | | 0.8 |
| | 3 GHz – 6 GHz | ≤20 | | 0.8 |
| Forward Direction Source Match | 300 kHz – 1.3 GHz | ≤16 | | 0.2 |
| | 1.3 GHz – 3 GHz | ≤16 | | 0.2 |
| | 3 GHz – 6 GHz | ≤12 | | 0.3 |
| Reverse Direction Trans. Tracking | 300 kHz – 1.3 GHz | 1.5 | | 0.006 |
| | 1.3 GHz – 3 GHz | 1.5 | | 0.009 |
| | 3 GHz – 6 GHz | 2.5 | | 0.021 |
| Forward Direction Refl. Tracking | 300 kHz – 1.3 GHz | 1.5 | | 0.001 |
| | 1.3 GHz – 3 GHz | 1.5 | | 0.005 |
| | 3 GHz – 6 GHz | 2.5 | | 0.020 |
| Reverse Direction Load Match | 300 kHz – 1.3 GHz | ≤18 | | 0.1 |
| | 1.3 GHz – 3 GHz | ≤16 | | 0.2 |
| | 3 GHz – 6 GHz | ≤14 | | 0.2 |

Performance Test Records
Option H39 Performance Test Record

| Model 8753ES Option H39 Serial Number | | | Report Number | |
|--|-------------------|------------|----------------------|--------------------|
| Option(s) | | | Date | |
| 9. Uncorrected Port Performance, Port 1 and Port 2 (continued) | | | | |
| Note: If your analyzer does not have Option 006, write "N/A" in all entries above 3 GHz. | | | | |
| Test Description | Frequency Range | Spec. (dB) | Measured Value (dB) | Meas. Uncert. (dB) |
| Forward Direction | | | | |
| Load Match | 300 kHz – 1.3 GHz | ≤18 | | 0.1 |
| | 1.3 GHz – 3 GHz | ≤16 | | 0.2 |
| | 3 GHz – 6 GHz | ≤14 | | 0.2 |
| Reverse Direction | | | | |
| Directivity | 300 kHz – 1.3 GHz | ≤35 | | 0.9 |
| | 1.3 GHz – 3 GHz | ≤30 | | 0.8 |
| | 3 GHz – 6 GHz | ≤20 | | 0.8 |
| Reverse Direction | | | | |
| Source Match | 300 kHz – 1.3 GHz | ≤16 | | 0.02 |
| | 1.3 GHz – 3 GHz | ≤16 | | 0.02 |
| | 3 GHz – 6 GHz | ≤12 | | 0.03 |
| Reverse Direction | | | | |
| Refl. Tracking | 300 kHz – 1.3 GHz | 1.5 | | 0.001 |
| | 1.3 GHz – 3 GHz | 1.5 | | 0.005 |
| | 3 GHz – 6 GHz | 2.5 | | 0.020 |
| Forward Direction | | | | |
| Trans. Tracking | 300 kHz – 1.3 GHz | 1.5 | | 0.006 |
| | 1.3 GHz – 3 GHz | 1.5 | | 0.009 |
| | 3 GHz – 6 GHz | 2.5 | | 0.021 |

| Model 8753ES Option H39 | | | Report Number | |
|--|-------|-----------------|----------------------|---------------|
| Serial Number | | | | |
| Option(s) | | | Date | |
| 10. System Trace Noise | | | | |
| Note: If your analyzer does not have Option 006, write "N/A" in all entries above 3 GHz. | | | | |
| Ratio | IF BW | Phase/Magnitude | Measured Value | Specification |
| Test Frequency: 3 GHz | | | | |
| A/R | 10 Hz | Magnitude | | <0.001 dB rms |
| A/R | 10 Hz | Phase | | <0.006 °rms |
| A/R | 3 kHz | Phase | | <0.038 °rms |
| A/R | 3 kHz | Magnitude | | <0.006 dB rms |
| B/R | 3 kHz | Magnitude | | <0.006 dB rms |
| B/R | 3 kHz | Phase | | <0.038 °rms |
| B/R | 10 Hz | Phase | | <0.006 °rms |
| B/R | 10 Hz | Magnitude | | <0.001 dB rms |
| Test Frequency: 6 GHz | | | | |
| A/R | 10 Hz | Magnitude | | <0.002 dB rms |
| A/R | 10 Hz | Phase | | <0.012 °rms |
| A/R | 3 kHz | Phase | | <0.070 °rms |
| A/R | 3 kHz | Magnitude | | <0.010 dB rms |
| B/R | 3 kHz | Magnitude | | <0.010 dB rms |
| B/R | 3 kHz | Phase | | <0.070 °rms |
| B/R | 10 Hz | Phase | | <0.012 °rms |
| B/R | 10 Hz | Magnitude | | <0.002 dB rms |

Performance Test Records
Option H39 Performance Test Record

| | | | | | | |
|--|---------------------------------|---|--|--|-----------------------|-----------------------------------|
| Model 8753ES Option H39 | | Report Number | | | | |
| Serial Number | | | | | | |
| Option(s) | | Date | | | | |
| 11. Test Port Receiver Magnitude Dynamic Accuracy (Test Port 3) | | | | | | |
| Note: If your analyzer does not have Option 006, write "N/A" in all entries above 3 GHz. | | | | | | |
| | | G | F | G - F | | |
| Test Port Input Power (dBm) | 8496A Attn. (dB) | Test Port Measurement (dB) | Expected Measurement (Corrected) (dB) | Dynamic Accuracy (Calculated) | Spec. (dB) | Meas. Uncert. (dB) |
| Test Port 3 | | | | | | |
| -10 | 0 | | | | ≤0.033 | 0.008 |
| -20 (ref) | 10 | | 0.000 | | ≤0.020 | 0.008 |
| -30 | 20 | | | | ≤0.031 | 0.008 |
| -40 | 30 | | | | ≤0.041 | 0.008 |
| -50 | 40 | | | | ≤0.054 | 0.008 |
| -60 | 50 | | | | ≤0.069 | 0.017 |
| -70 | 60 | | | | ≤0.111 | 0.017 |
| -80 | 70 | | | | ≤0.257 | 0.017 |
| -90 | 80 | | | | ≤0.741 | 0.017 |
| -100 | 90 | | | | ≤2.121 | 0.027 |

| | | | | | | |
|--|---------------------------------|---|--|--|-----------------------|-----------------------------------|
| Model 8753ES Option H39 | | Report Number | | | | |
| Serial Number | | | | | | |
| Option(s) | | Date | | | | |
| 11. Test Port Receiver Magnitude Dynamic Accuracy (Test Port 1) | | | | | | |
| Note: If your analyzer does not have Option 006, write "N/A" in all entries above 3 GHz. | | | | | | |
| | | G | F | G - F | | |
| Test Port Input Power (dBm) | 8496A Attn. (dB) | Test Port Measurement (dB) | Expected Measurement (Corrected) (dB) | Dynamic Accuracy (Calculated) | Spec. (dB) | Meas. Uncert. (dB) |
| Test Port 1 | | | | | | |
| -10 | 0 | | | | ≤0.033 | 0.008 |
| -20 (ref) | 10 | | 0.000 | | ≤0.020 | 0.008 |
| -30 | 20 | | | | ≤0.031 | 0.008 |
| -40 | 30 | | | | ≤0.041 | 0.008 |
| -50 | 40 | | | | ≤0.054 | 0.008 |
| -60 | 50 | | | | ≤0.069 | 0.017 |
| -70 | 60 | | | | ≤0.111 | 0.017 |
| -80 | 70 | | | | ≤0.257 | 0.017 |
| -90 | 80 | | | | ≤0.741 | 0.017 |
| -100 | 90 | | | | ≤2.121 | 0.027 |

Performance Test Records
Option H39 Performance Test Record

| | | | | |
|--|----------------------|-------------|--------------------|------------------------------|
| Model 8753ES Option H39 | Report Number | | | |
| Serial Number | | | | |
| Option(s) | Date | | | |
| 12. Test Port Receiver Magnitude Compression | | | | |
| Note: If your analyzer does not have Option 006, write "N/A" in all entries above 3 GHz. | | | | |
| | Measured Value | | | |
| CW Frequency | Test Port 3 | Test Port 1 | Specification (dB) | Measurement Uncertainty (dB) |
| 300 kHz | | | ≤0.45 | 0.04 |
| 50 MHz | | | ≤0.45 | 0.04 |
| 1 GHz | | | ≤0.45 | 0.04 |
| 1.65 GHz | | | ≤0.45 | 0.04 |
| 2 GHz | | | ≤0.2 | 0.04 |
| 3 GHz | | | ≤0.2 | 0.04 |
| 4 GHz | | | ≤0.80 | 0.5 |
| 5 GHz | | | ≤0.80 | 0.5 |
| 6 GHz | | | ≤0.80 | 0.5 |

| | | | | |
|--|-----------------------|--------------------|------------------------------------|------------------------------------|
| Model 8753ES Option H39 | Report Number | | | |
| Serial Number | | | | |
| Option(s) | Date | | | |
| 13. Test Port Receiver Phase Compression | | | | |
| Note: If your analyzer does not have Option 006, write "N/A" in all entries above 3 GHz. | | | | |
| | Measured Value | | | |
| CW Frequency | Test Port 3 | Test Port 1 | Specification (degrees) | Measurement Uncertainty |
| 300 kHz | | | $\leq 6^\circ$ | 0.3° |
| 50 MHz | | | $\leq 6^\circ$ | 0.3° |
| 1 GHz | | | $\leq 6^\circ$ | 0.3° |
| 1.65 GHz | | | $\leq 6^\circ$ | 0.3° |
| 2 GHz | | | $\leq 6^\circ$ | 0.3° |
| 3 GHz | | | $\leq 7.5^\circ$ | 0.3° |
| 4 GHz | | | $\leq 7.5^\circ$ | 0.4° |
| 5 GHz | | | $\leq 7.5^\circ$ | 0.4° |
| 6 GHz | | | $\leq 7.5^\circ$ | 0.4° |

Performance Test Records
Option H39 Performance Test Record

| Model 8753ES Option H39 | | Report Number | |
|--|----------------------------|--------------------------------|-------------------------------------|
| Serial Number | | | |
| Option(s) | | Date | |
| 14. Test Port Output/Input Harmonics (Option 002 only) | | | |
| Note: If your analyzer does not have Option 006, write "N/A" in all entries about 3 GHz. | | | |
| Test Description | Specification (dBc) | Measurement Value (dBc) | Measurement Uncertainty (dB) |
| Test Port Output Harmonics | | | |
| 2nd | ≤ -25 | | 1.5 |
| 3rd | ≤ -25 | | 1.5 |
| | | | |
| Port 1 Input Harmonics | | | |
| 2nd | ≤ -15 | | 1.5 |
| 3rd | ≤ -30 | | 1.5 |
| | | | |
| Port 3 Input Harmonics | | | |
| 2nd | ≤ -15 | | 1.5 |
| 3rd | ≤ -30 | | 1.5 |

| Model 8753ES Option H39 | | | | | Report Number | | | |
|--|-------------------|-------------------|------------|---------------------------------|---------------------------------|-----|------------|--------------------|
| Serial Number | | | | | | | | |
| Option(s) | | | | | Date | | | |
| 15. Harmonic Measurement Accuracy (Option 002 only) | | | | | | | | |
| Note: If your analyzer does not have Option 006, write "N/A" in all entries above 3 GHz. | | | | | | | | |
| Analyzer Freq. | Ext. Source Freq. | Power Meter Meas. | Cable Loss | (A) Power Meter + Cable Loss | (B) Network Analyzer Reading | A-B | Spec. (dB) | Meas. Uncert. (dB) |
| 20 MHz | 40 MHz | | | | | | 1.5 | ±0.17 |
| 20 MHz | 60 MHz | | | | | | 1.5 | ±0.17 |
| 100 MHz | 200 MHz | | | | | | 1.5 | ±0.17 |
| 100 MHz | 300 MHz | | | | | | 1.5 | ±0.17 |
| 300 MHz | 600 MHz | | | | | | 1.5 | ±0.17 |
| 300 MHz | 900 MHz | | | | | | 1.5 | ±0.17 |
| 500 MHz | 1 GHz | | | | | | 1.5 | ±0.17 |
| 500 MHz | 1 GHz | | | | | | 1.5 | ±0.17 |
| 1 GHz | 2 GHz | | | | | | 1.5 | ±0.17 |
| 1 GHz | 2 GHz | | | | | | 1.5 | ±0.17 |
| 2 GHz | 4 GHz | | | | | | 3.0 | ±0.17 |
| 2 GHz | 6 GHz | | | | | | 3.0 | ±0.17 |
| 3 GHz | 6 GHz | | | | | | 3.0 | ±0.17 |

3 **Theory of Operation and
Troubleshooting**

This chapter provides basic theory of operation and troubleshooting information for the analyzer. This information is intended to be used as a guide in finding and correcting possible problems that could be experienced with Option H39. Component locations, cable diagrams, and other aides are supplied in this section of the service guide. If the information provided is not enough to remedy the problem, refer to your standard documentation. It is recommended that all service be done in an ESD safe environment. Read the safety and ESD information in the standard documentation before doing any work on the analyzer.

Theory of Operation

Three-Port Test Set

The 8753ES Option H39 includes a three-port signal-separation test set that routes signals from any two ports to the A and B receiver channel samplers. Refer to [Figure 3-12 on page 3-25](#) and [Figure 3-13 on page 3-26](#) for the component locations and RF paths.

Option H39 adds a third test port to the standard 8753ES test set. Three test ports allow measurement applications for three-port devices with the ability to make S-parameter measurements between any two test ports. This option adds four additional solid-state switches, RF cabling to redirect the RF source, and the A and B channel receiver inputs.

Port 1 is configured to operate as in a standard instrument, while Port 2 and Port 3 are switched in and out by one additional solid-state switch. The A and B channel receiver inputs are redirected through a matrix of three solid-state switches that connect directly to the coupled arm of each test port coupler. Test ports are controlled by the internal TTL I/O signals. Test ports are type-N.

A network analyzer with this option will have slightly degraded output power levels, accuracy, and dynamic range.

NOTE

With Option H39, test port bias can only be supplied to Port 1 from the Port 1 bias connector on the rear panel. The Port 2 bias connector on the rear panel is not connected.

Port 1 and Port 3 are the instrument's default ports. On preset, or when power is turned on, Port 1 and Port 3 are active.

Test Port Couplers

The analyzer's test port couplers are used to separate signals incident to, reflected from, and transmitted by the device under test. Each test port coupler has a coupling factor of 16 dB.

LED Front Panel

The front panel LEDs indicate whether the test port is the incident port, the receiver port, or the inactive port. The test port LED that is the brightest is the incident port. The test port LED that is dim is the receiver port. The test port LED that is off is the inactive port where no signal separation is taking place. When performing a forward transmission or reflection measurement, the analyzer's source power is directed to Port 1. This is indicated by a bright LED. If the Port 2 LED is dim, this is the receiver port. The Port 3 LED is off in this condition and is inactive. Only two LEDs are on at any given time.

Transfer Switch S0

The A3 source output is directed via a low-loss solid-state switch. With this switch, all four S-parameters can be measured continuously. In addition, the transfer switch provides termination for the receiver test port in order to minimize the crosstalk between source and receiver sampler.

Port 2 and 3 Source Switch S1

S1 is the source separator for Port 2 and Port 3. In addition, the Port 2 and Port 3 source switch provides termination for the inactive test port to minimize the crosstalk to either source and receiver sampler and provide a load match to the device under test.

A Sampler Receiver Switch S2

Provides reflected or transmitted measured signals from Port 1 or Port 2 to the A channel sampler.

B Sampler Receiver Switch S3

Provides reflected or transmitted measured signals from Port 2 or Port 3 to the B channel sampler.

Port 2 Receiver Switch S4

Provides reflected or transmitted signals from Port 2 to be directed to either A or B channel samplers.

Test Set Interface

The test set interface board provides biasing for active devices under test with an external dc voltage. Only Port 1 can provide bias. Bias supplied to Port 1 is applied directly to the center conductor pin. In addition, the test set interface board provides the drive signals for all internal solid-state switches.

Troubleshooting

This section only covers troubleshooting techniques for the three-port test set with the **3PORT** mode off. To turn the **3PORT** mode off, press **System**, **CONFIGURE MENU**, **OPTION HXX CONFIG**, **3PORT MODE** and toggle to **OFF**. For information on troubleshooting other portions of the analyzer, refer to the standard documentation.

Required Equipment

| Description | Model Number or Part Number |
|--------------------------------|-----------------------------|
| Calibration Kit, 50Ω Type-N | 85032B |
| Power Meter | 436A, 437A, 438A |
| Sensor | 8481A |
| RF Cable 50Ω Type-N (m) to (m) | part number 8120-4781 |

Table 3-1

Test Set I/O Port Parameters

| Measurements | Ports and Port Paths | S-parameters Under Meas Menu | Test Set I/O Setting | Test Set I/O Setting |
|--------------|----------------------|------------------------------|----------------------|----------------------|
| | | | FWD | REV |
| Reflection | 1) Port 1 | S_{11} | 7 | --- |
| | 2) Port 2 | S_{22} | 6 | 5 |
| | 3) Port 3 | S_{33} | --- | 7 |
| Transmission | 4) Port 1-Port 3 | S_{31}, S_{13} | 7 | 7 |
| | 5) Port 2-Port 3 | S_{32}, S_{23} | 6 | 6 |
| | 6) Port 1-Port 2 | S_{21}, S_{12} | 5 | 5 |

Source Test

This source troubleshooting section tests the functionality of the test port(s) in question.

1. Connect the equipment as shown in [Figure 3-1](#).

Figure 3-1

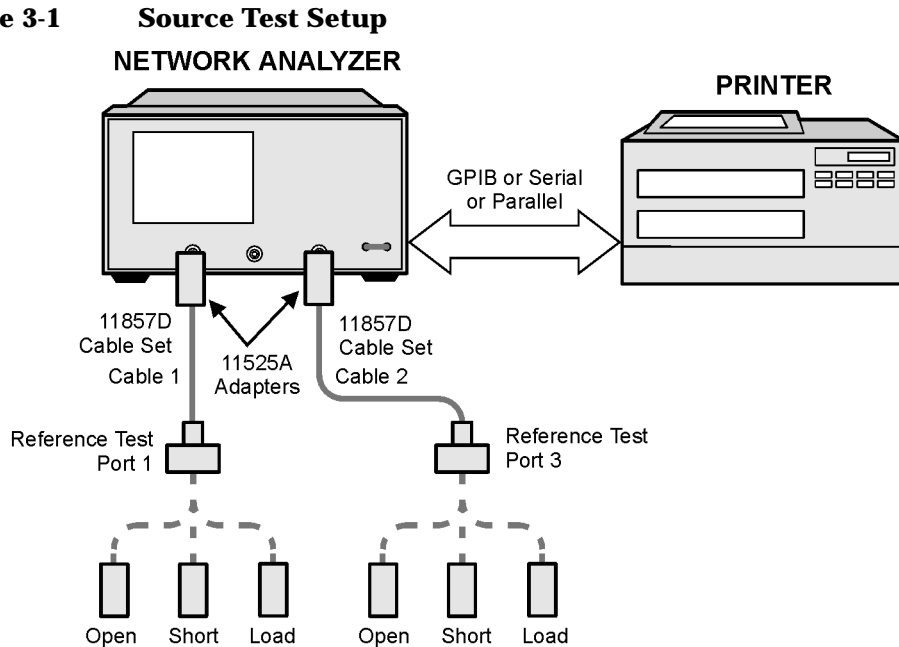

ue54o

2. Press **Preset, Sweep Setup, CW FREQ**. The default frequency is 1 GHz.
3. To measure Port 1, make sure the analyzer is in a forward state by pressing:
 - **Preset, Meas, REFL: FWD S11 (A/R)** or
 - **Seq, TTL I/O, TTL OUT, TESTSET I/O FWD**, toggle to 7.
4. Make a note of the reading on the power meter.
5. To measure Port 2 in the forward state, press **Seq, TTL I/O, TTL OUT, TESTSET I/O FWD**, toggle to 6.
6. Move the power sensor to Port 2.
7. Press **Meas, REFL: FWD S22 (A/R)**.

Theory of Operation and Troubleshooting

Troubleshooting

8. To measure Port 2 in the reverse state, press **Preset, Meas, REFL: REV S22 (A/R)**.
9. Make a note of the reading on the power meter.
10. Press **Meas, REFL: REV S22 (B/R)**.
11. Press **Seq, TTL I/O, TTL OUT, TESTSET I/O REV, 5, x1**.
12. Make a note of the reading on the power meter.
13. To measure Port 3, make sure the analyzer is in a reverse state and set the **TESTSET I/O REV** to 7.
14. Move the power sensor to Port 3.
15. Press **Meas, REFL: REV S33 (B/R)**.
16. Make a note of the reading on the power meter.
17. Compare the relative power at the test ports in question. If the power indicated by the power meter is relative to the test port power, see the following note; then proceed to the receiver section.

NOTE

Port 1 will measure 9 dBm. Port 2 and 3 will measure -2 dBm.

Symptom 1: No RF Source at All Test Ports

The A3 source may be the problem. Refer to the standard documentation for source problems. If the A3 source is verified and working, proceed to [“Symptom 2: No RF Source at Port 1”](#) next.

Symptom 2: No RF Source at Port 1

Check the bias connection to the switch S0 (see [Figure 3-13](#)) and the J3 connections (see [Figure 3-17](#)) on the test set interface board. If the bias connector is loose, reconnect it. If the bias connector is firmly in place in the J3 connector, check the bias voltages on the switch S0 (+0.62 Vdc and +16.3 Vdc). The center bias pin on S0 should be approximately 22 V.

1. Use the tab on the side of one of the switches (S0, S1, S2) as the ground connection point.
2. The red wire is the common drive pin and should measure approximately +22 V.
3. The blue wire is the solenoid drive for pin number one. The voltage on this pin measures approximately +0.62 V.
4. The green wire is the solenoid drive for pin number two. The voltage on this pin measures approximately +16.3 V.
5. Measure the solenoid voltages using the following procedure.

NOTE

Voltages may vary depending on the test port state of the instrument.

- a. Press **Preset, Meas.**
- b. Toggle between **REFL: FWD S11 (A/R)** and **REFL: REV S22 (B/R)** while measuring bias pins 1 and 2 on S0. The bias voltage on bias pins 1 and 2 should alternate between +0.62 Vdc and +16.3 Vdc when the instrument is toggled from **REFL: FWD S11 (A/R)** and **REFL: REV S22 (B/R)**. If the bias voltage changes state but there is still no RF at Port 1, the transfer switch S0 may need to be replaced.

Before replacing switch S0, check the receiver section for Port 1 to make sure the test port coupler is functioning correctly. If the bias voltage remains the same, check the LEDs to make sure the source test port is being redirected. When the instrument is toggled from **REFL: FWD S11 (A/R)** to **REFL: REV S22 (B/R)**, the bright LED indicates the incident port and the dim LED indicates the receiver port.

If the LEDs are working on Port 1 and Port 3 and the bias voltage is still incorrect on switch S0, move the S1 bias connector from J6 to J3 (see [Figure 3-17](#)) on the test set interface board. Press **Seq**, **TTL I/O**, **TTL OUT**, **TESTSET I/O FWD**, **6**, **x1**, **I/O REV**, **6**, **x1**. Check the bias voltage (+0.62 Vdc and + 16.3 Vdc) on S1 (see [Figure 3-13](#)). Toggle the instrument between the **REFL: FWD S11 (A/R)** and **REFL: REV S22 (B/R)** states. If the bias voltage does not change, replace the test set interface board. If the bias voltage does change, replace S0.

Symptom 3: RF Source at Test Port 1

No RF Source at Test Ports 2 or 3 or Both

Check the bias connection to switch S1 (see [Figure 3-13](#)) and the J6 connection (see [Figure 3-17](#)) on the test set interface board. If the bias connector is loose, reconnect it. If the bias connector is firmly in place in the J3 connector, check the bias voltages (+0.62 Vdc and +16.3 Vdc) on switch S1. The center bias pin on S1 should be approximately +22 V.

1. Use the tab on the side of one of the switches (S0, S1, or S2) as the ground connection point.
2. The red wire is the common drive pin and should measure approximately +22 V.
3. The blue wire is the solenoid drive for pin number one. The voltage on this pin measures approximately +16.3 V.
4. The green wire is the solenoid drive for pin number two. The voltage on this pin measures approximately +0.62 V.
5. Measure the solenoid voltages.

NOTE

Voltages may vary depending on the test port state of the instrument.

- a. Press **Preset**, **Meas**.
- b. Press **Seq**, **TTL I/O**, **TTL OUT**, **TESTSET I/O FWD**, **6**, **x1**.
- c. Toggle between **REFL: FWD S11 (A/R)** and **REFL: REV S22 (B/R)** while measuring bias pins 1 and 2 on S1.

The voltage on bias pins 1 and 2 should alternate between +0.62 Vdc and +16.3 Vdc when the instrument is toggled from REFL: FWD S11 (A/R) and REFL: REV S22 (B/R). If the bias voltage changes state but there is still no RF at Port 2 in the forward state or no RF at Port 3 in the reverse state, the transfer switch S1 may need to be replaced.

Before replacing switch S1, check Port 2 and Port 3 in the receiver section to make sure the test port couplers are functioning correctly. If Port 2 and Port 3 are working correctly and the bias voltage remains the same, check the LEDs to make sure the source test port is being redirected. When the instrument is toggled from REFL: FWD S11 (A/R) to REFL: REV S22 (B/R), the bright LED indicates the incident port and the dim LED indicates the receiver port.

If the LEDs are working on Port 2 and Port 3 and the bias voltage is still incorrect on switch S1, move the S0 bias connector from J3 to J6 (see [Figure 3-17](#)) on the test set interface board. Check the bias voltage (+0.62 Vdc and + 16.3 Vdc) on S1 (see [Figure 3-13](#)). Toggle the instrument between the REFL: FWD S11 (A/R) and REFL: REV S22 (B/R) states. If the bias voltage does not change, replace the test set interface board. If the bias voltage changes, replace S1.

Receiver Section Test

This section only covers the Option H39 area of the receiver. This is only a function test to verify that an RF signal can be received by either the A or B channel samplers. When making your measurements refer to [Figure 3-4](#), [Figure 3-5](#), and [Figure 3-6](#) as examples of an irregular or degraded response.

Port 3 Test

Connect the analyzer as shown in [Figure 3-2](#).

Figure 3-2

Receiver Setup

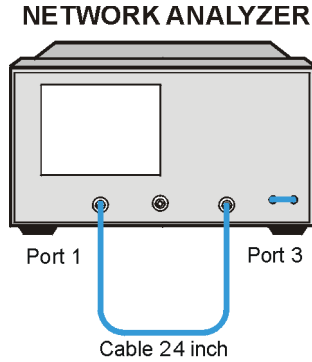

ue515c

Figure 3-3

Good Port 3 B Channel Response

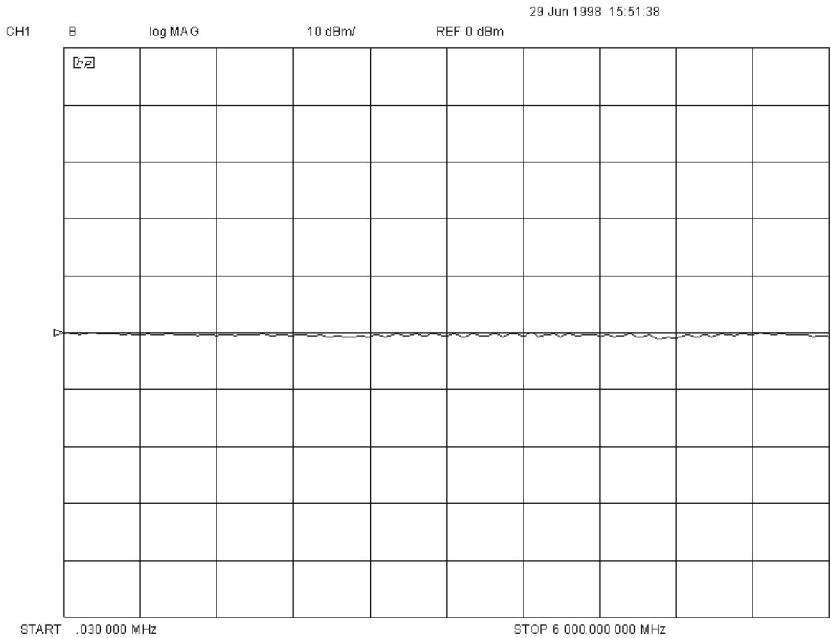

pg690h

1. Press **Preset, Meas, Start, 300, k/m, INPUT PORTS, B, TESTPORT 1**.
2. If there is a power hole or roll off in the response, check the RF cables. Refer to [Figure 3-14](#), [Figure 3-15](#), and [Figure 3-16](#) for cable locations.

If no response is seen for channel B, check the bias connection to switch S2 (see [Figure 3-13](#)) and the J5 connection (see [Figure 3-17](#)) on the test set interface board. If the connector is loose, reconnect it. If the bias connector is firmly in place in the J5 connector, check the bias voltages on switch S2 (+0.62 Vdc and +16.3 Vdc). The center bias pin on S2 should be approximately +22 V.
3. Use the tab on the side of one of the switches (S0, S1, S2) as the ground connection point.
4. The red wire is the common drive pin and should measure approximately +22 Vdc.
5. The blue wire is the solenoid drive for pin number one. The voltage on this pin measures approximately +0.62 Vdc.
6. The green wire is the solenoid for pin number two. The voltage on this pin measures approximately +16.3 Vdc.
7. Measure the solenoid voltages.

NOTE

Voltages may vary depending on the test port state of the instrument.

- a. Press **Seq, TTL I/O, TTL OUT, TESTSET I/O FWD, 5, x1, I/O FWD, 7, x1**.
- b. Toggle between **5, x1** and **7, x1** while measuring bias pins 1 and 2 on S2.

The voltage on bias pins 1 and 2 should alternate between +0.62 Vdc and +16.3 Vdc when the instrument is toggled from **5, x1** to **7, x1**. If the bias voltage changes state but there is still no RF at Port 1, the transfer switch S2 (see [Figure 3-13](#)) may need to be replaced. If the bias voltage remains the same, check the LEDs to make sure the source test port is being redirected.

Theory of Operation and Troubleshooting

Troubleshooting

When the instrument is toggled from Port 1 to Port 3 and from Port 1 to Port 2, the bright LED should remain on Port 1. If the LEDs are working on Port 1 to Port 3 and Port 1 to Port 2, and the bias voltage is still incorrect on switch S2, remove the J5 bias connector (see [Figure 3-17](#)) from the test set interface board and move the S4 bias connector from J14 to J5 on the test set interface board. Check the bias voltage on S4 and toggle between the **TESTSET I/O FWD, 5, x1** and **TESTSET I/O FWD, 7, x1** states. If the bias voltage does not change, replace the test set interface board. If the bias voltage does change, replace S2.

If the B channel response is degraded or a bad load match exists on Port 3, this may indicate a bad test port coupler. To check the load match on Port 3, follow the instructions on the verification procedure in this service guide.

Figure 3-4 **Roll Off**

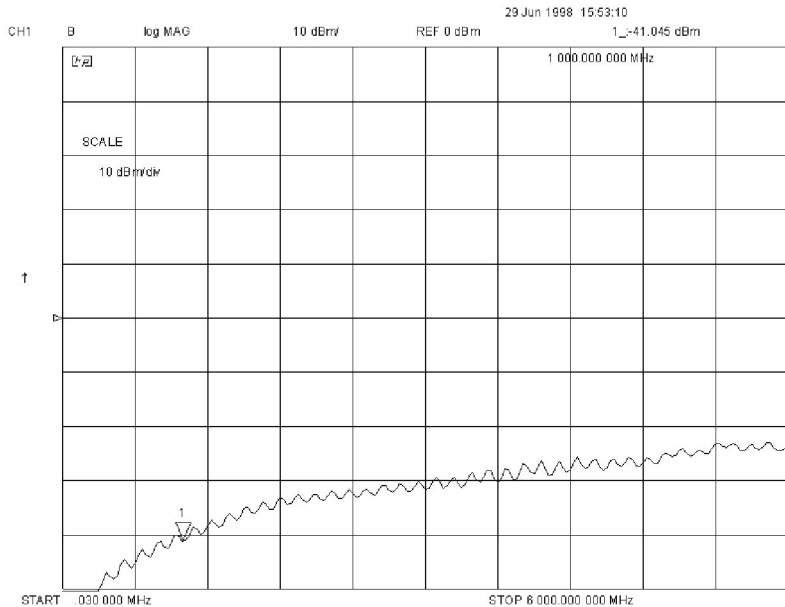

pg699h

Figure 3-5 Power Hole

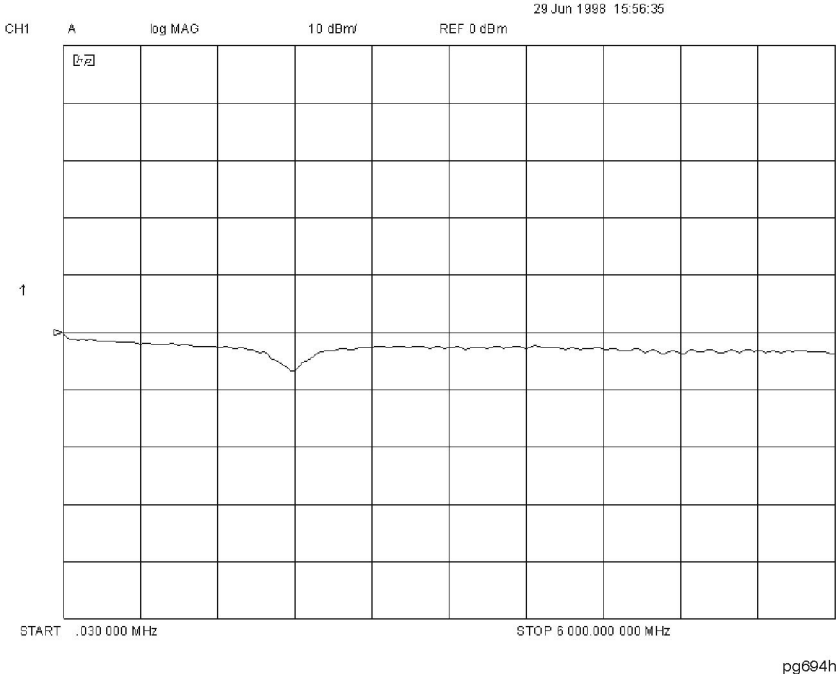
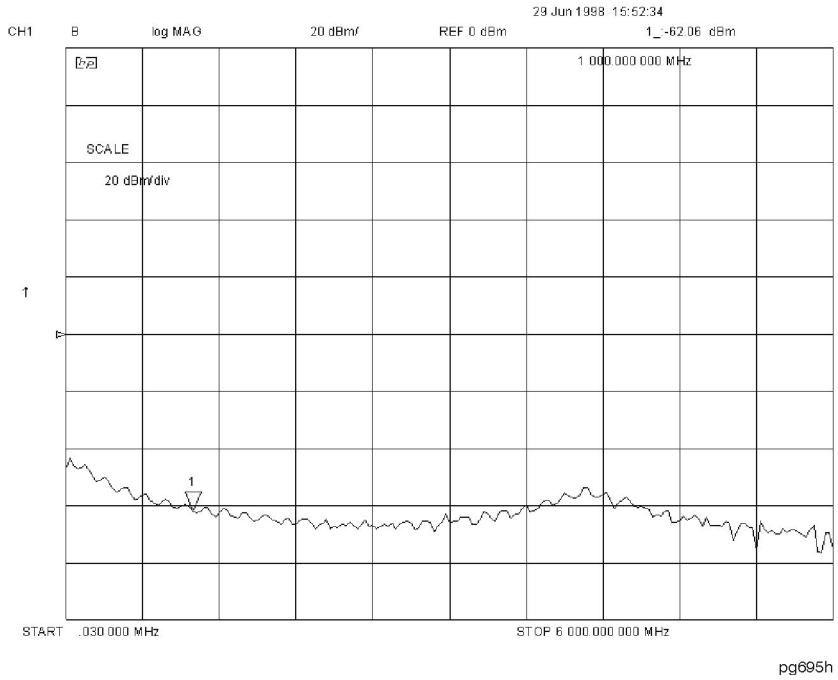
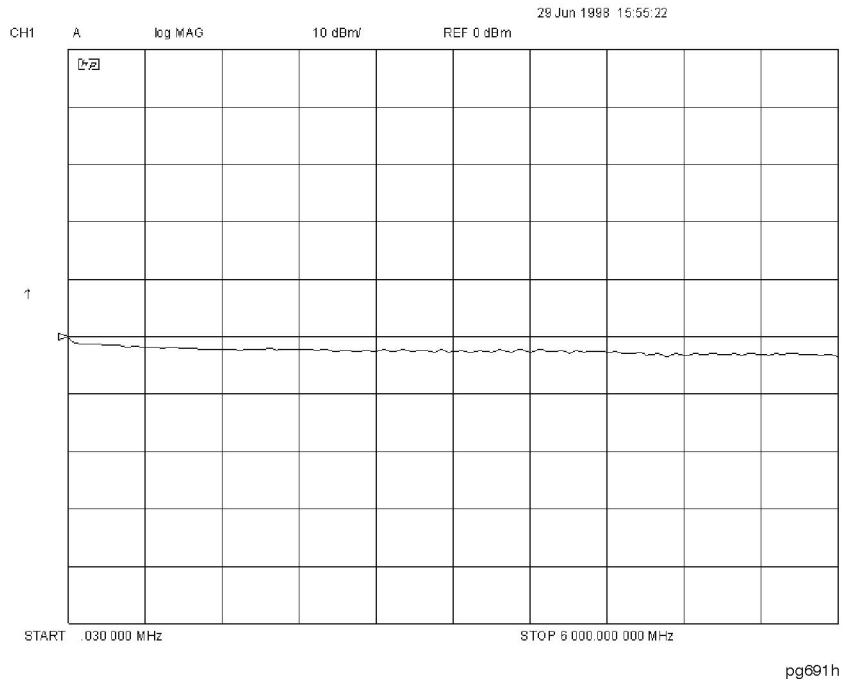

Figure 3-6 **Loose Switch Bias Connector**



Port 1 Test

Figure 3-7 Good Port 1 A Channel Response



With the analyzer connected as shown in [Figure 3-2](#), press **Preset, Start, 300, k/m, Meas, INPUT PORTS, A, TESTPORT 2**.

If there is a power hole or roll off in the response, check the RF cables. Refer to [Figure 3-14](#), [Figure 3-15](#), or [Figure 3-16](#) for cable locations.

If no response is seen for channel A, check the bias connection to switch S3 (see [Figure 3-13](#)) and the J4 connections (see [Figure 3-17](#)) on the test set interface board. If the bias connector is loose, reconnect it. If the bias connector is firmly in place in the J4 connector, check the bias voltages (+0.62 Vdc and +16.3 Vdc) on switch S3. The center bias pin on S3 should be approximately +22 V.

1. Use the tab on the side of one of the switches (S0, S1, S2) as the ground connection point.
2. The red wire is the common drive pin and should measure approximately +22 Vdc.

Theory of Operation and Troubleshooting

Troubleshooting

3. The blue wire is the solenoid drive for pin number one. The voltage on this pin measures approximately +0.62 Vdc.
4. The green wire is the solenoid for pin number two. The voltage on this pin measures approximately +16.3 Vdc.
5. Measure the solenoid voltages.

NOTE

Voltages may vary depending on the test Port state of the instrument.

- a. Press **Seq, TTL I/O, TTL OUT, TESTSET I/O REV, 6, x1, I/O REV, 7, x1**.
- b. Toggle between **6, x1** and **7, x1** while measuring bias pins 1 and 2 on S3.

The voltage on bias pins 1 and 2 should alternate between +0.62 Vdc and +16.3 Vdc when the instrument is toggled from **6, x1** to **7, x1**. If the bias voltage changes state but there is still no RF at Port 1, the transfer switch S3 (see [Figure 3-13](#)) may need to be replaced. If the bias voltage remains the same, check the LEDs to make sure the source test port is being redirected.

When the instrument is toggled from Port 3 to Port 1 and Port 3 to Port 2, the bright LED should remain on Port 3. If the LEDs are working on Port 3 to Port 1, and the bias voltage is still incorrect on switch S3, disconnect the J4 connector (see [Figure 3-17](#)) and check the bias voltage on S4 (+0.62 Vdc and +16.3 Vdc). Toggle between the **TESTSET I/O REV, 6, x1** and **TESTSET I/O REV, 7, x1** states. If the bias voltage does not change, replace the test set interface board. If the bias voltage does change, replace S3.

If the A channel response is degraded and a bad load match exists on Port 1, this may indicate a bad test port coupler. To check the load match on Port 1, follow the instructions on the verification procedure in this service guide. Replace the Port 1 coupler if the Port 1 load match fails.

Port 2 Test

1. Connect the analyzer as shown in [Figure 3-8](#).

Figure 3-8

Receiver Setup 2

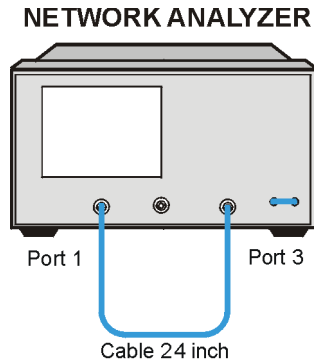

ue515c

2. Press **Preset, Start, 300, k/m, Meas, INPUT PORTS, A, TESTPORT 2.**
3. Press **Seq, TTL I/O, TTL OUT, TESTSET I/O REV, 6, x1.**

Figure 3-9 **Good Port 2 A Channel Response**

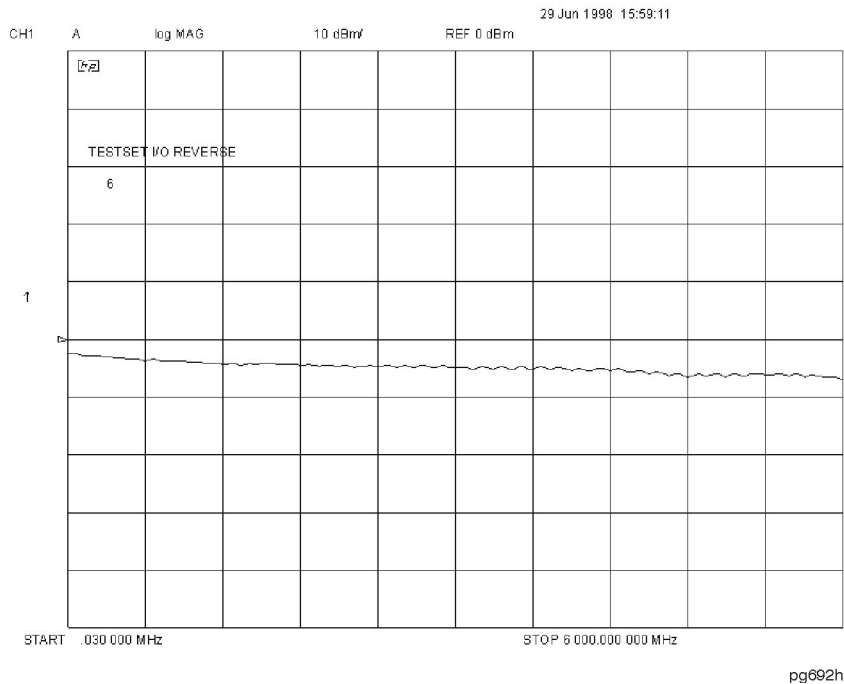

If there is a power hole or roll off in the response, check the RF cables. Refer to [Figure 3-14](#), [Figure 3-15](#), or [Figure 3-16](#) for cable locations.

If no response is seen for channel A, check the bias connection to switch S4 (see [Figure 3-13](#)) and the J14 connection (see [Figure 3-17](#)) on the test set interface board. If the bias connector is loose, reconnect it. If the bias connector is firmly in place in the J14 connector, check the bias voltages (+0.62 Vdc and +16.3 Vdc) on switch S4. The center bias pin on S4 should be approximately +22 V.

1. Use the tab on the side of one of the switches (S0, S1, S2) as the ground connection point.
2. The red wire is the common drive pin and should measure approximately +22 Vdc.
3. The blue wire is the solenoid drive for pin number one. The voltage on this pin measures approximately +16.3 Vdc.

4. The green wire is the solenoid for pin number two. The voltage on this pin measures approximately +0.62 Vdc.
5. Measure the solenoid voltages.

NOTE

Voltages may vary depending on the test port state of the instrument.

- a. Press **Seq, TTL I/O, TTL OUT, TESTSET I/O REV, 6, x1, I/O REV, 5, x1**.
- b. Toggle between **6, x1** and **5, x1** while measuring bias pins 1 and 2 on S4.

The voltage on bias pins 1 and 2 should alternate between +0.62 Vdc and +16.3 Vdc when the instrument is toggled between **6, x1** and **5, x1**. If the bias voltage changes state but there is still no RF at Port 1, the transfer switch S4 may need to be replaced. If the bias voltage remains the same, check the LEDs to make sure the source test port is being redirected.

When the instrument is toggled from Port 3 to Port 2 and Port 2 to Port 1, the bright LED should change from Port 3 to Port 2. If the LEDs are working on Port 3 to Port 2 and Port 1 to Port 2, and the bias voltage is still incorrect on switch S4, disconnect J14 (see [Figure 3-17](#)) and check the bias voltage on S3 (see [Figure 3-13](#)). Toggle the instrument between the **TESTSET I/O REV, 6, x1** and **TESTSET I/O REV, 5, x1** states. If the bias voltage changes, replace S4. If the bias voltage does *not* change, replace the test set interface board.

If the A channel response is degraded and a bad load match exists on Port 2, this may indicate a bad test port coupler. To check the load match on Port 1, follow the verification procedure instructions in this service guide. Replace the Port 1 coupler if Port 1 load match fails.

1. Connect the analyzer as shown in [Figure 3-10](#).

Figure 3-10

Power Meter Calibration for Magnitude Dynamic Accuracy

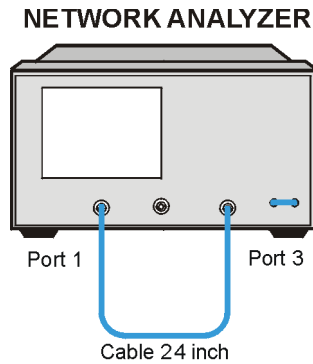

ue515c

2. Press **Preset, Start, 300, k/m, Meas, INPUT PORTS, B, TESTPORT 1.**
3. Press **Seq, TTL I/O, TTL OUT, TESTSET I/O FWD, 5, x1.**

Figure 3-11 Good Port 2 B Channel Response

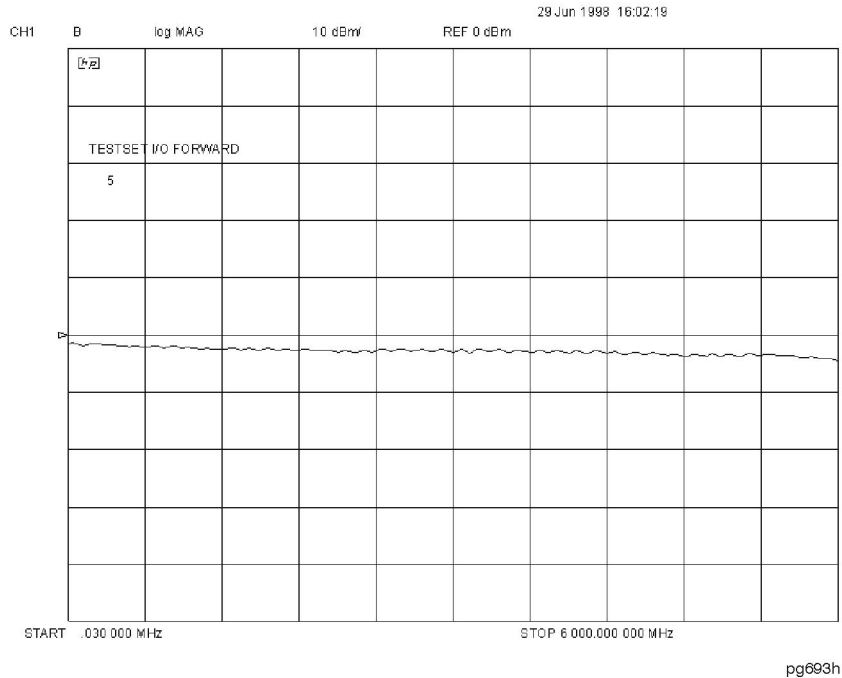

If there is a power hole or roll off in the response, check the RF cables. Refer to [Figure 3-14](#), [Figure 3-15](#), or [Figure 3-16](#) for cable locations.

If no response is seen for channel B, check the bias connection to switch S4 (see [Figure 3-13](#)) and the J14 connection (see [Figure 3-17](#)) on the test set interface board. If the bias connector is loose, reconnect it. If the bias connector is firmly in place in the J14 connector, check the bias voltages (+0.62 Vdc and +16.3 Vdc) on switch S4. The center bias pin on S4 should be approximately +16.3 V.

1. Use the tab on the side of one of the switches (S0, S1, S2) as the ground connection point.
2. The red wire is the common drive pin and should measure approximately +22 Vdc.
3. The blue wire is the solenoid drive for pin number one. The voltage on this pin measures approximately +0.62 Vdc.

Theory of Operation and Troubleshooting

Troubleshooting

4. The green wire is the solenoid for pin number two. The voltage on this pin measures approximately +16.3 Vdc.
5. Now measure the solenoid voltages.

NOTE

Voltages may vary depending on the test port state of the instrument.

- a. Press **Seq, TTL I/O, TTL OUT, TESTSET I/O FWD, 6, x1, I/O FWD, 5, x1**.
- b. Toggle between **6, x1** and **5, x1** while measuring bias pins 1 and 2 on S4.

The voltage on bias pins 1 and 2 should alternate between +0.62 Vdc and +16.3 Vdc when the instrument is toggled between **6, x1** and **5, x1**. If the bias voltage changes state but there is still no RF at Port 1, the transfer switch S4 may need to be replaced. If the bias voltage remains the same, check the LEDs to make sure the source test port is being redirected.

When the instrument is toggled from Port 1 to Port 2 and Port 2 to Port 3, the bright LED will change from Port 1 to Port 2. If the LEDs are working on Port 1 to Port 2 and Port 2 to Port 3, and the bias voltage is still incorrect on switch S4, disconnect the J14 connector (see [Figure 3-17](#)) and check the bias voltage on S3 (see [Figure 3-13](#)). Toggle the instrument between **TESTSET I/O FWD, 6, x1** and **TESTSET I/O FWD, 5, x1**. If the bias voltage changes, replace S4. If the bias voltage does *not* change, replace the test set interface board.

If the B channel response is degraded and a bad load match exists on Port 2, this may indicate a bad test port coupler. To check the load match on Port 2, follow the verification procedure instructions in this service guide. Replace the Port 1 coupler if the Port 1 load match fails.

Figure 3-12 Option H39 Block Diagram

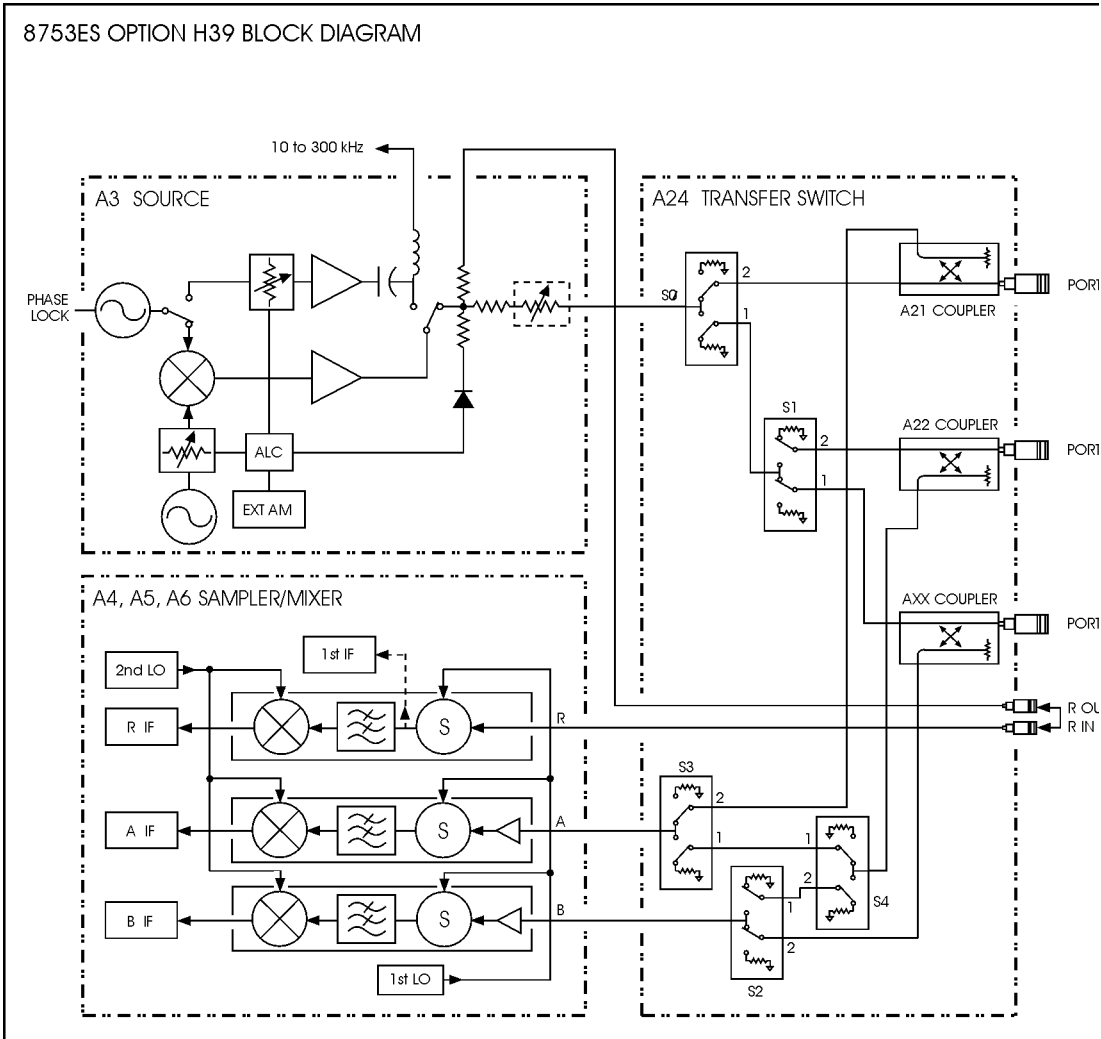
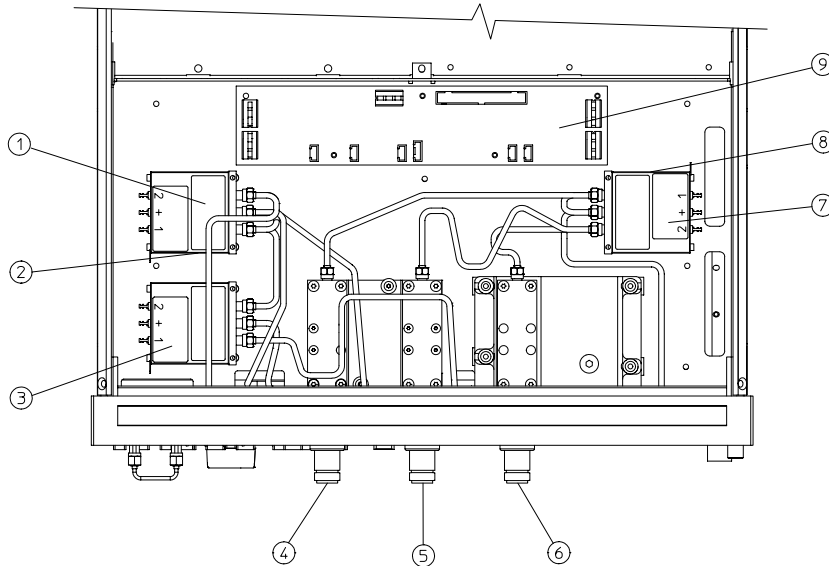

Figure 3-13 Option H39 Bottom Major Components



pg686h

Major Assemblies

| Item | Description |
|-------------|-----------------------------|
| 1 | Switch, Top S3 |
| 2 | Switch, Bottom S4 |
| 3 | Switch, S2 |
| 4 | Port 3 |
| 5 | Port 2 |
| 6 | Port 1 |
| 7 | Switch, Top S1 |
| 8 | Switch, Bottom S0 |
| 9 | Test Set Interface PC Board |

Figure 3-14 Option H39 Bottom Assembly Cables

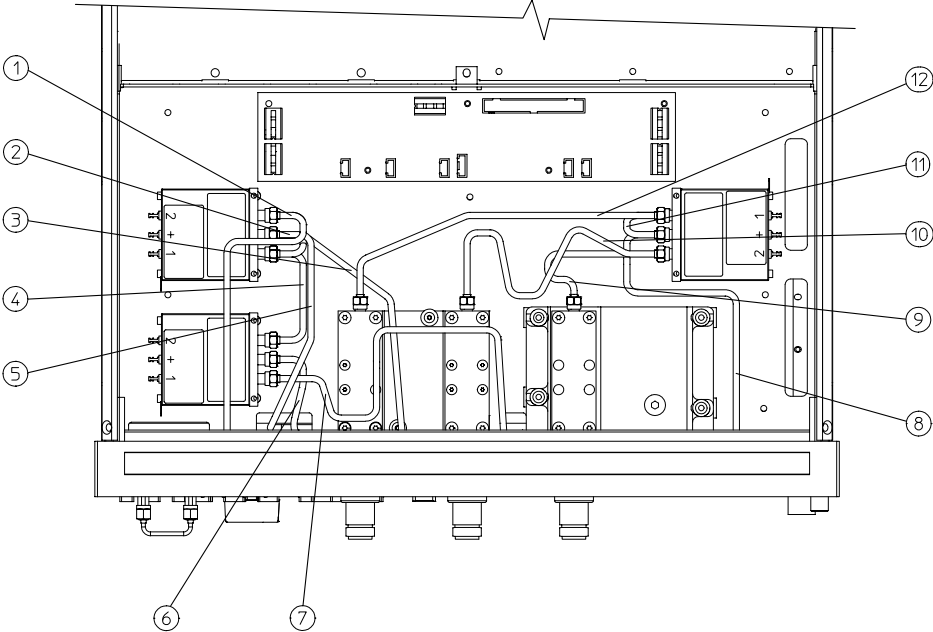

pg687h

Bottom Cable Descriptions

| Item | Description | Part Number |
|------|---------------------------------|-------------|
| 1 | Cable, Switch 2-2 to AXX | 08753-20347 |
| 2 | Cable, Switch 2-1 to Switch 4-2 | 08753-20352 |
| 3 | Cable, Switch 4-C to A22 | 08753-20346 |
| 4 | Cable, Switch 3-1 to Switch 4-1 | 08753-20348 |
| 5 | Cable, B Sampler to Switch 2-C | 08753-20322 |
| 6 | Cable, A Sampler to Switch 3-C | 08753-20353 |
| 7 | Cable, Switch 3-1 to A21 | 08753-20345 |
| 8 | Cable, Source to Switch 0-C | 08753-20354 |
| 9 | Cable, Switch 0-2 to A21 | 08753-20317 |
| 10 | Cable, Switch 1-2 to A22 | 08753-20343 |
| 11 | Cable, Switch 0-1 to Switch 1-C | 08753-20342 |
| 12 | Cable, Switch 1-1 to AXX | 08753-20344 |

Figure 3-15 **Option H39 Assembly Top Cables**

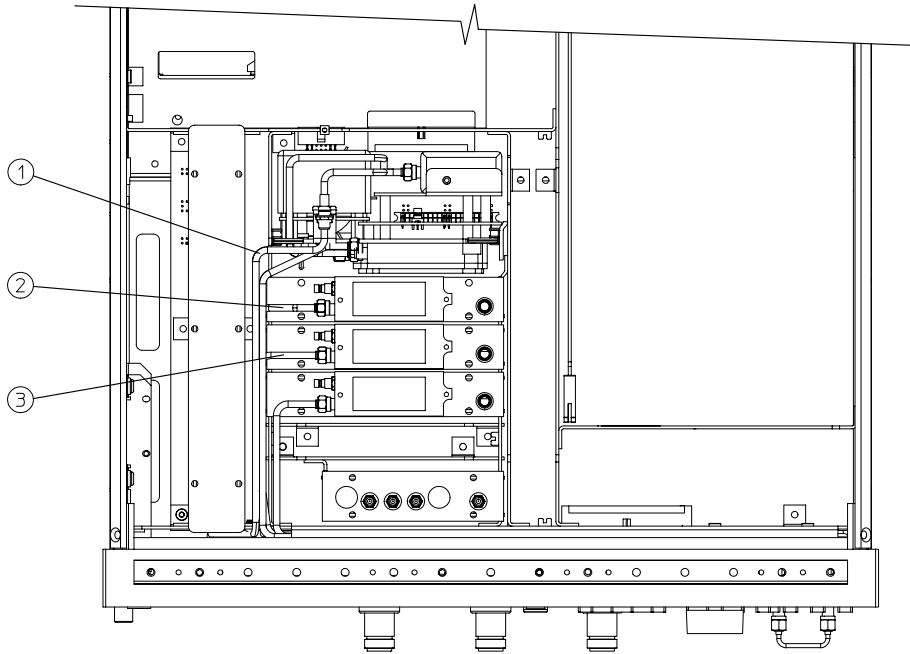

pg688h

Option H39 Assembly Top Cables

| Item | Description | Part Number |
|-------------|--------------------------------|--------------------|
| 1 | Cable, Source to Switch 0-C | 08753-20354 |
| 2 | Cable, B Sampler to Switch 2-C | 08753-20322 |
| 3 | Cable, A Sampler to Switch 3-C | 08753-20353 |

Figure 3-16 **Option H39 Assembly Front**

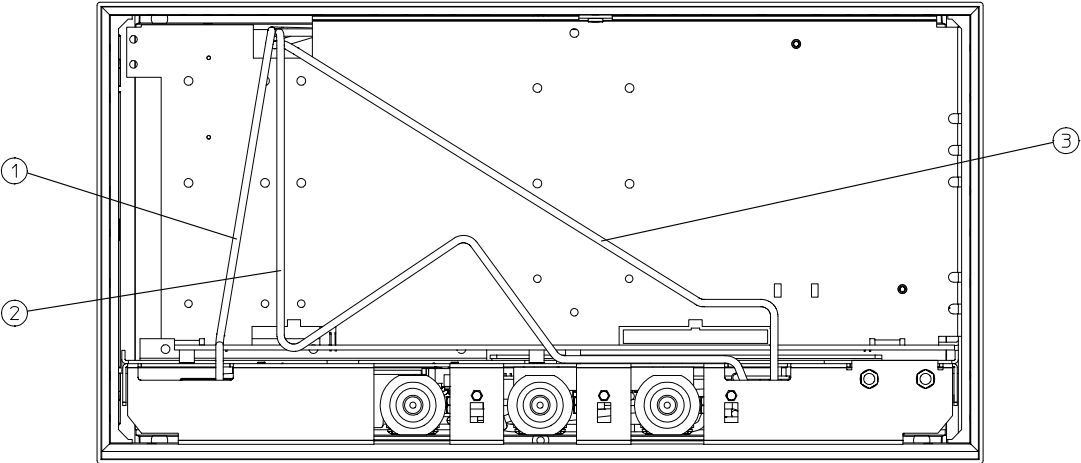

pg689h

Option H39 Assembly Front

| Item | Description | Part Number |
|-------------|--------------------------------|--------------------|
| 1 | Cable, Source to Switch 0-C | 08753-20354 |
| 2 | Cable, A Sampler to Switch 3-C | 08753-20353 |
| 3 | Cable, B Sampler to Switch 2-C | 08753-20322 |

Figure 3-17 **Interface PC Board Connector Reference**

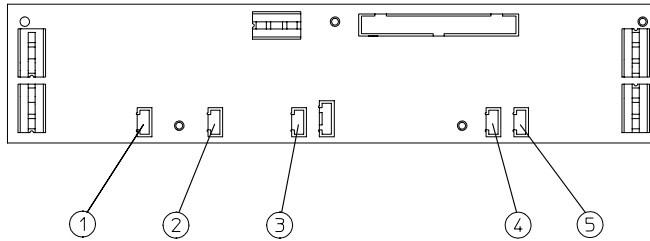

pg6129h

Front Cable Descriptions

| Item | Description |
|-------------|--------------------|
| 1 | Connector J4 |
| 2 | Connector J14 |
| 3 | Connector J5 |
| 4 | Connector J3 |
| 5 | Connector J6 |

4

**Replaceable Parts and
Post-Repair Procedure**

Replaceable Parts

Table 4-1 contains the list of replaceable parts for the Option H39 test set. If any of these parts or assemblies are replaced, you must perform all performance tests to verify conformance to specifications. For information on other parts or assemblies in the network analyzer, refer to your standard 8753ES *Service Guide*.

Table 4-1 Replaceable Parts and Post-Repair Procedures

| Replacement Part | Part Number | Post-Repair Procedures |
|----------------------------|-------------|------------------------|
| Switch–Solid State | 5086-7539 | All Performance Tests |
| Type–N Coupler | 5087-7050 | All Performance Tests |
| Port Coupler Type–N (f) | 5087-7054 | All Performance Tests |
| Test Set Deck | 08753-00149 | All Performance Tests |
| RF Cable S0–2 to A21 | 08753-20317 | All Performance Tests |
| RF Cable B Sampler to S0–C | 08753-20322 | All Performance Tests |
| Coupler Block | 08753-20324 | All Performance Tests |
| RF Cable S0–1 to S1–C | 08753-20342 | All Performance Tests |
| RF Cable S1–2 to A22 | 08753-20343 | All Performance Tests |
| RF Cable S1–1 to AXX | 08753-20344 | All Performance Tests |
| RF Cable S3–2 to A21 | 08753-20345 | All Performance Tests |
| RF Cable S4–C to A22 | 08753-20346 | All Performance Tests |
| RF Cable S2–2 to AXX | 08753-20347 | All Performance Tests |
| RF Cable S3–1 to S4–1 | 08753-20348 | All Performance Tests |
| RF Cable S2–1 to S4–2 | 08753-20352 | All Performance Tests |
| RF Cable A Sampler to S3–C | 08753-20353 | All Performance Tests |
| RF Cable Source to S0–C | 08753-20354 | All Performance Tests |
| Board Assembly–Test Set | 08753-60327 | All Performance Tests |
| Right Front Panel Assembly | 08753-60913 | All Performance Tests |
| CA 06C 06F LED | 08753-60920 | All Performance Tests |

Safety and Regulatory Information

General

The following safety notes and symbols are used throughout this manual and the standard documentation. Familiarize yourself with the symbols and their meanings before operating this instrument.

WARNING

Warning denotes a hazard. It calls attention to a procedure which, if not correctly performed or adhered to, could result in injury or loss of life. Do not proceed beyond a warning note until the indicated conditions are fully understood and met.

CAUTION

Caution denotes a hazard. It calls attention to a procedure that, if not correctly performed or adhered to, could result in damage to or destruction of the instrument. Do not proceed beyond a caution sign until the indicated conditions are fully understood and met.

Safety Symbols



The instruction documentation symbol. The product is marked with this symbol when it is necessary for the user to refer to the instructions in the documentation.



This symbol is used to mark the on position of the power line switch.



This symbol is used to mark the standby position of the power line switch.



This symbol indicates that the input power required is AC.

Safety Earth Ground

WARNING

This is a Safety Class 1 Product (provided with a protective earthing ground incorporated in the power cord). The mains plug shall only be inserted in a socket outlet provided with a protected earth contact. Any interruption of the protective conductor inside or outside of the product is likely to make the product dangerous. Intentional interruption is prohibited.

WARNING

If this product is not used as specified, the protection provided by the equipment could be impaired. This product must be used in a normal condition (in which all means for protection are intact) only.

Before Applying Power

Verify that the product is configured to match the available main power source as described in the input power configuration instructions in the standard manual.

If this product is to be powered by an autotransformer, make sure the common terminal is connected to the neutral (grounded) side of the AC power supply.

Table 4-2 Contacting Agilent

Online assistance: www.agilent.com/find/assist

| | | |
|---|--|---|
| United States (tel) 1 800 452 4844 | Japan (tel) (+81) 426 56 7832 (fax) (+81) 426 56 7840 | New Zealand (tel) 0 800 738 378 (fax) (+64) 4 495 8950 |
| Canada (tel) 1 877 894 4414 (fax) (905) 282 6495 | Latin America (tel) (305) 269 7500 (fax) (305) 269 7599 | |
| Europe (tel) (+31) 20 547 2323 (fax) (+31) 20 547 2390 | Australia (tel) 1 800 629 485 (fax) (+61) 3 9210 5947 | |

Asia Call Center Numbers

| Country | Phone Number | Fax Number |
|----------------------------|--|--|
| Singapore | 1-800-375-8100 | (65) 836-0252 |
| Malaysia | 1-800-828-848 | 1-800-801664 |
| Philippines | (632) 8426802 1-800-16510170 (PLDT Subscriber Only) | (632) 8426809 1-800-16510288 (PLDT Subscriber Only) |
| Thailand | (088) 226-008 (outside Bangkok) (662) 661-3999 (within Bangkok) | (66) 1-661-3714 |
| Hong Kong | 800-930-871 | (852) 2506 9233 |
| Taiwan | 0800-047-866 | (886) 2 25456723 |
| People's Republic of China | 800-810-0189 (preferred) 10800-650-0021 | 10800-650-0121 |
| India | 1-600-11-2929 | 000-800-650-1101 |